

CBT rapid contactors

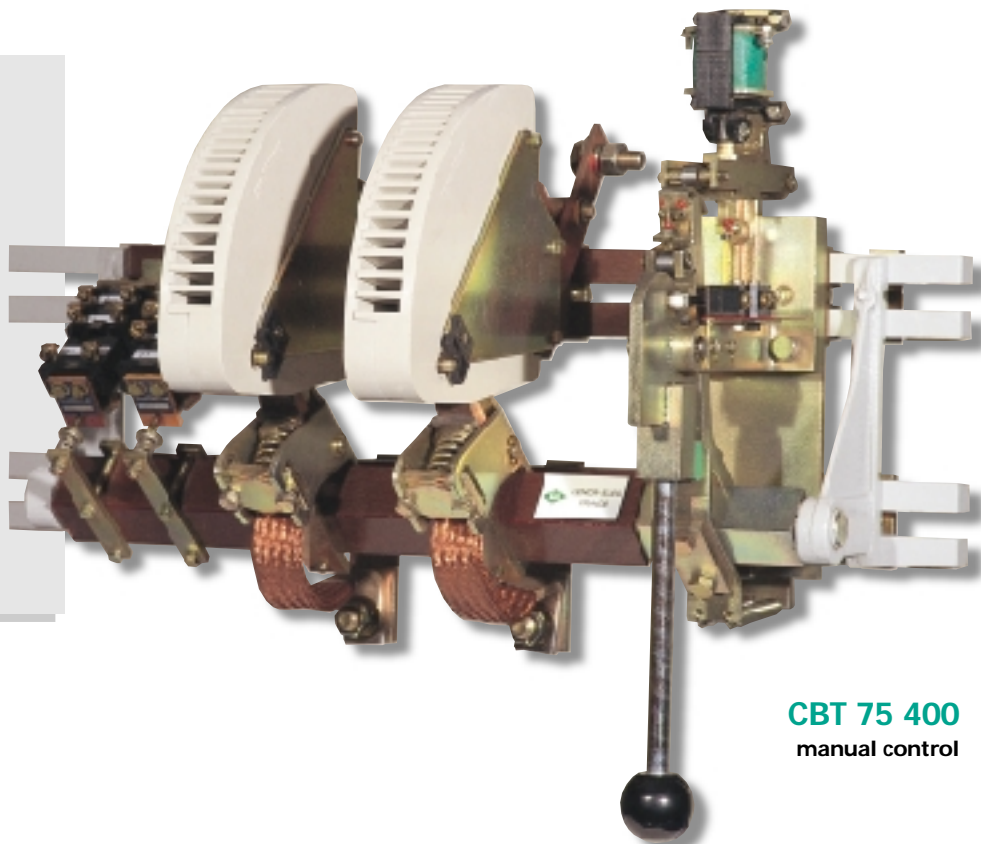

CBT 200,
CBT 400,
CBT 800.



CBT 75 400
manual control

General

The equipment composed of the fast opening system DS1 + rapid opening contactor CBT may be used for other applications than the ones described in the present chapter. However, the general rules of application remain the same.

We know that some commanded rectifier bridges, of «all thyristor» type may restore the energy to the network by operating as UPS units. This is the case for example of a GRAETZ bridge connected to a driving load motor.

This type of operation is also found in case of motors connected to rectifier bridges (constituted of two GRAETZ bridges assembled opposite) capable of ensuring the operation during the four quadrants of the «speed torque» diagram.

During the UPS operation, if the network voltage suddenly abnormally drops, the electromotive force of the load is no more opposed to the one of the network. Moreover, as the control pulses of the thyristors' UPS bridge generally, go on energizing then, this short-circuit closes very fast directly in one or several vertical branches of the bridge.

Ultra-rapid fuses, playing their normal part of protection melt in more or less significant number. If there are no fuses in the branches of the bridges, the thyristors will be the ones, by being put off load, to stop the output of the load on that short-circuit, but only after the current had reached high ratings.

For rectifier bridges that:

- are to operate on networks subject to frequent voltage disruptions or,
- have to ensure significant duty factors as UPS units.

The probability of defect is high enough to make it interesting to foresee an additional selective protection, capable of opening the connection between the load and the bridge before the energy created in the fuses generates their fusion or partial degradation.

All the more so, the thyristors are also protected by this protective system.

This last one should include:

- a rapid switch off device - the «rapid CBT contactor» and,
- a CBT contactor instant control device in case the current would exceed a pre-fixed value - the fast opening system DS1.

Those elements and eventually the outer circuit must be scheduled and adjusted so that at the end of the cut off, the energy dissipated in the fuses and thyristors shouldn't cause any damage.

We know that for the fuses, this limit is defined by the manufacturers by the integral $\int i^2 dt$ of pre-arc.

Same thing for the thyristors, an integral $\int i^2 dt$ of fusion, not to reach or exceed, has to be defined



41. CBT 200 - 400 - 800

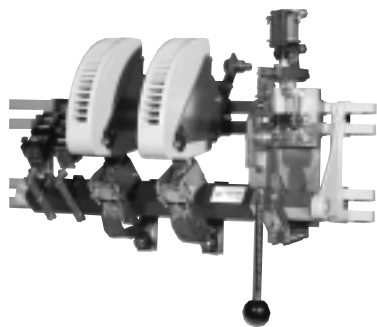

CBT 400 Manual closing

Use

Such a contactor is used to complete the protection of thyristors bridges supplying the DC motors in case of disappearance of the AC supply voltage. Coupled with an electronic current detector, the CBT contactor opens fast enough to:

- avoid the fusion of the ultra-rapid fuses.
- limit the current to a value inferior to the one that would create a clash to the motor's commutator.
- limit the $\int i^2 dt$ value to a doorstep very inferior to the present possibilities of thyristors.

Description

- 1 or 2 magnetic arc-blowout closing poles.
- Closing
 - CBT 200: electrical closing thanks to a solid magnetic circuit controlled by an auxiliary contactor,
 - CBT 400 and 800: manual closing with handle or electrical closing with a separated laminated magnetic circuit controlled by an auxiliary contactor or manual & electrical closing.
- Mechanical latching with electrical release on CBT 200 (manual release on request), mechanical latching with electrical and manual releases on CBT 400 and 800 A.
- Instant M type auxiliary contacts (the contacts for switching-off the closing and tripping coils are mounted and cabled).
Free auxiliary contacts: 1 NO + 1 NC on CBT 200 and CBT 400 & 800 with electrical control, 1 NO + 2 NC on CBT 400 & 800 with manual control.
- Possible addition of 1 or 2 extra M3 blocks, (increases the overall dimensions of the CBT).
Contactors with manual control are equipped with:
 - a safety contact (opened during the operation of the handle),
 - a padlocking facility, on request.

Technical features

		CBT 200	CBT 400	CBT 800
Insulating voltage		V 1000	1000	1000
Nominal DC voltage				
	single-pole break	V 250	300	300
	two-pole break	V 500	600	600
Current of use		A 300	500	1000
	minimum section to connect	mm ² 185	240	500
Current switch-off rating L/R = 15 ms, U re-established-550 V continuous		A 4000	8000	16000
Arcing voltage		V 1200	1900	1900
Time of rise of arcing voltage (7 ms < L/R < 37 ms)		ms < 5	< 5	< 5
Arcing time (L/R = 15 ms)		ms 14	14	14
Control circuit				
	closing (direct or rectified current ⁽²⁾)	standard voltages V 110 - 200	110 - 127 - 220 - 380	110 - 127 - 220 - 380
		absorbed power W 660	2300	2300
		closing time at Un ms 95	80	80
	opening ⁽³⁾	current A 27	27	27
		quantity of electricity coulomb 0.1	0.1	0.1
		allowable permanent current A 1.1	1.1	1.1
		pulse time ms 18	18	18
Opening time between command and separation of contacts		ms 8 - 9	8 - 9	8 - 9
Mechanical endurance		operations 75000	15000	15000
Use		connection ⁽¹⁾		
		1 contactor	2 contactors	
Current of use	Voltage of use	1P	2P in series	2P in parallel
A	V			
300	250	●	-	-
	500	-	●	-
500	300	●	-	-
	600	-	●	-
600	300	-	●	-
	600	-	-	●
1000	300	●	-	-
	600	-	●	-
2000	300	-	●	-
	600	-	-	●

(1) from the current of use and the voltage of use depend the connection of contactors.
 (2) exclusively via a rectifier (not supplied).
 (3) either in 220 V dc or via a capacitors' discharge of 1300 µF (Voltage of charge: 250 V).