

Semiconductor Fuse Applications Guide



FERRAZ SHAWMUT IS NOW MERSEN

MERSEN

Semiconductor Fuse Applications Guide

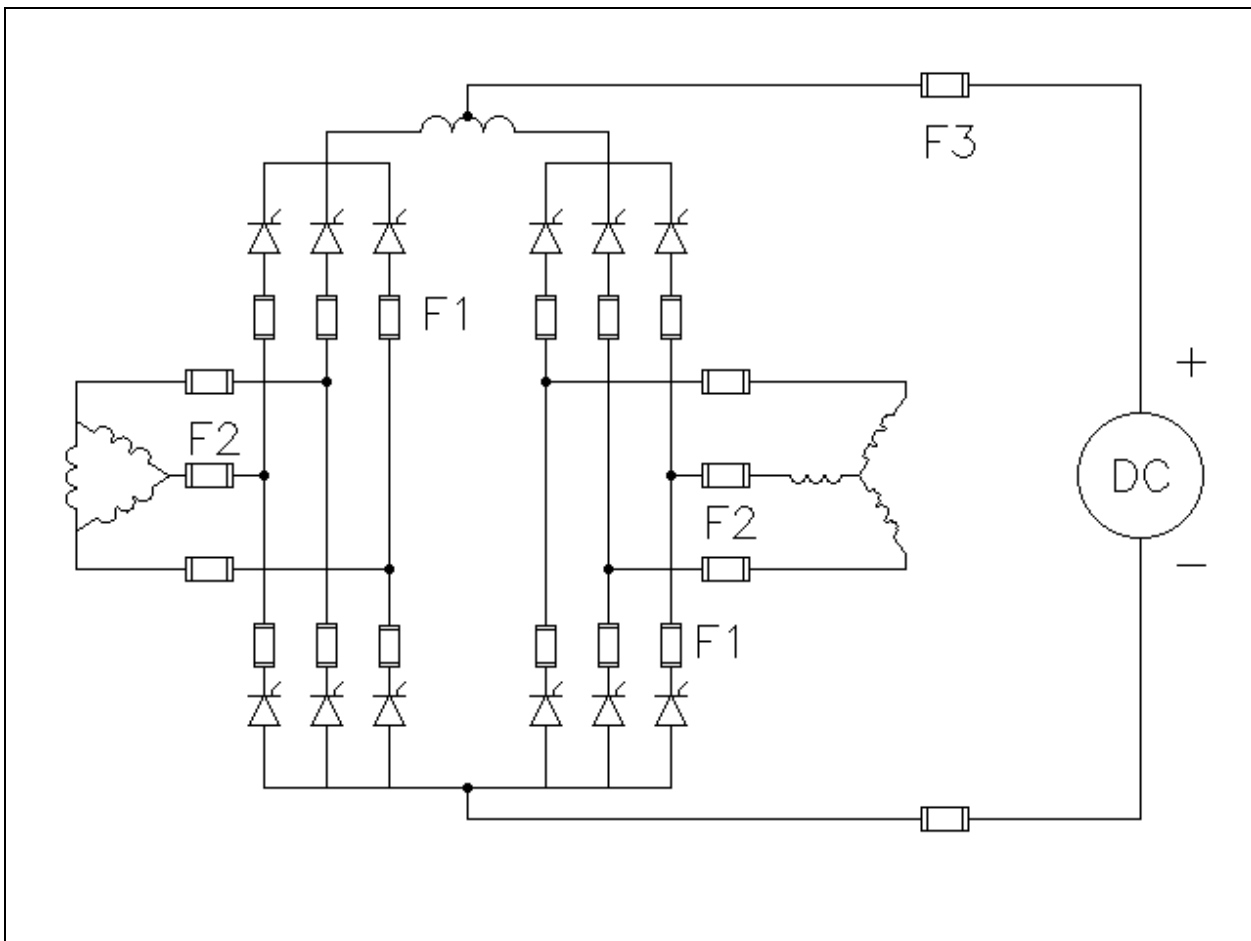

© Mersen (formerly Ferraz Shawmut), January 2002

Contents

	Page
1. Introduction	2
2. Continuous current rating I_n	3
3. Protection against overcurrents - basic concepts	3
4. The time-current characteristic	4
5. Adjusting the fuse rated current to allow for real-world working conditions	5
6. Estimation of fuse life under cyclic overloads	8
7. Occasional (non-repetitive) overload coefficient C_{f3}	10
8. Short-circuit currents	11
9. Current-limiting operation	12
10. Interruption of d.c. fault currents	17
11. Surge withstand of semiconductor devices	18
12. 3-phase controlled bridge rectifier	20
13. Converters with multiple parallel devices	23
14. Regenerative loads	25
15. AC controllers (soft-starters, static switches)	28
16. Forced commutated inverters	29
17. Fuse selection examples	32
18. Select-A-Fuse for Power Electronics (SAF/PE)	36
19. Problem solved using SAF/PE	38
20. Appendix	42
21. Mersen Technical Services Contacts	46

1. Introduction

A fuse is a device for protecting an electrical system against the effects of overcurrents (excess currents), by melting one or more fuse-elements, thus opening the circuit. Very fast-acting fuses are widely used for the protection of diodes, thyristors, and other power semiconductors in a.c. and d.c. power electronic applications, and provide excellent protection against the potentially damaging effects of short-circuit currents.

Current-limiting fuses achieve this protection by limiting both the amount of energy produced during an overcurrent and also the peak current which is allowed to flow.

The term 'semiconductor fuse' means a very fast-acting fuse specifically intended *for the protection of power semiconductors*.

Fig.1 shows the construction of a typical semiconductor fuse. The fuse elements are usually made of pure silver strips, with regions of reduced cross-sectional area (often called *notches*). There may be several strips in parallel, depending on the ampere rating of the fuse. They are enclosed within an insulating tube or ceramic body, which is filled with pure quartz sand. At each end there are terminals with a variety of designs to permit installation in fuse-holders or connection to busbars.

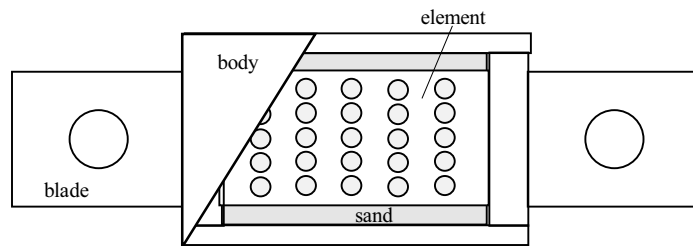

Fig.1 Construction of a typical semiconductor protection fuse

Fuses such as that shown in Fig.1, with the elements surrounded by sand, are called **current-limiting**, or **high breaking capacity** fuses. Semiconductor fuses are sometimes referred to as rectifier or ultra-fast fuses. They are available with voltage ratings up to 12.5kV, and with rated currents up to 10000A.

During normal circuit operation the fuse elements carry the required currents without melting. The resistance is as low as possible to minimize the power loss. However, when a short-circuit or fault occurs, the elements melt very quickly at the notches (regions of reduced cross-sectional area), and a number of small electric arcs are produced in the notch zones, which causes the fault current to be rapidly reduced to zero, and the arcs extinguish. The total time taken by a fuse to clear a fault is the sum of the melting time (*pre-arcing time*) and the arcing time.

Special fuse designs are needed to provide protection of power electronic components. The *p-n* semiconductor junction can be very easily damaged, and so a very fast-acting fuse is required. For example, a typical thyristor may fail when subjected to a 10ms (one half-cycle in a 50Hz system) pulse of only 10 times its nominal r.m.s. current rating. A low-voltage fuse designed for general industrial applications may require 15-30 times its ampere rating to melt within 10ms, which is not fast enough to provide protection, whereas a very fast-acting semiconductor fuse typically requires only about 5-6 times its ampere rating, thus protecting the thyristor.

2. Continuous current rating I_n

The rated current (I_n) of a fuse is a value assigned by the manufacturer, and is the r.m.s. current which the fuse is designed to carry continuously under specified test conditions. In this respect it is no different from the rated current of any other electrical device. I_n is established by testing the fuse under standard conditions specified in fuse standards (such as UL or IEC). Test fixtures with standard sizes for the connecting cables or busbars are used, with the fuse cooled by free air.

The current rating alone does not provide the user with any information about a fuse's protective characteristics. The temperatures of the various parts of a fuse must be kept within acceptable limits when it is carrying rated current. For example, the temperature at the middle of a silver fuse element must be much lower than the melting point of silver (960.5°C), and this means that the rated current will be considerably lower than the minimum current required to cause the elements to melt. For semiconductor fuses the maximum allowable temperature rises are determined by the manufacturer.

In real-world applications, the working conditions of a fuse inside equipment are rarely the same as those used in the standard type test. Since the rated current is based upon the temperature-rises produced under steady-state thermal conditions in the lab, operating a fuse under different thermal conditions may change the current carrying capability of the fuse. The user must take this into account when applying the fuse. (See section 5).

3. Protection against overcurrents - basic concepts

Overcurrents can be roughly classified into two groups; overloads and short-circuits.

Overloads

The term "overload" is used for excess current flowing in a circuit which is electrically sound. Overload currents are usually not much greater than the normal full-load current of the system, but if allowed to persist will eventually cause damage. Damage to the system, especially to insulating materials in contact with the circuit conductors, can result, due to the heating effect of the current. The heating time is relatively long (from seconds up to several hours), and the overload can therefore be characterized by the **r.m.s. value** of the overload current. For overload protection, the requirement for a protective device is that it should limit the duration of the overload current. Most semiconductor fuses are not designed to provide protection against long-duration overloads. Electronic or other means must be used to switch the circuit off when overloads occur. However new style gR semiconductor fuses can provide overload protection as low as 160% of fuse rated current. Consult the Mersen datasheets for precise values.

Short-circuits

Short-circuits are usually due to a catastrophic electrical failure, such as insulation breakdown or accidental conditions, and the resulting r.m.s. value of the prospective (available) short-circuit current is high, typically more than 20 times the normal full-load current of the system. The heating effect is so rapid that damage to the system can occur within milliseconds, which is of the same order as the duration of an a.c. half-cycle. The heating effect cannot be characterized by the r.m.s. value of the prospective (available) current, as in the case of overloads, because it depends upon the **waveform** of the current.

In this case the requirement for the protective device is to limit the energy associated with the fault, which depends upon the integral

$$\int_0^t i^2 dt$$

where i is the instantaneous current [i.e. $i = i(t)$]. This integral is usually called the " I^2t " and is a measure of the thermal energy delivered to each ohm of the circuit by the short-circuit current during the time t .

An additional requirement for a short-circuit protective device is that it should also limit the **peak value** of current permitted to flow in the circuit. **Electromagnetic forces** are dependent on the square of the instantaneous current and may produce mechanical damage to equipment. If short-circuit currents are allowed to flow unchecked, after the mechanical damage to the components of the circuit, melting of circuit conductors can occur and be followed by arcing between the molten fragments, possibly causing fires and hazards to personnel as well as the further destruction of the electrical system. High-speed semiconductor fuses open very rapidly under short circuit conditions thus providing excellent protection in case of short-circuit faults.

4. The time-current characteristic

If a fuse is subjected to a current greater than the minimum current required to produce melting, the fuse element will melt. The higher the current, the shorter the *melting time* will be. This inverse relationship is shown graphically by the **time-current characteristic (TCC)**. Fig.2 shows a typical time-current characteristic for a semiconductor fuse with a nominal current rating of 450A.

The time it takes for a fuse element to melt is often referred to as the *prearcing time*, since melting is followed by a period of arcing. Melting of a fuse element is due to the heating effect of the current, which depends on the r.m.s. value of the current *actually flowing* through the fuse before melting occurs. For operation in times less than one a.c. cycle, the melting time of the element is greatly affected by the waveshape of the current. In this case it is necessary to use I^2t values for checking the system protection. (See section 8). The standard time current curve shown in Fig.2 is for a symmetrical sinewave.

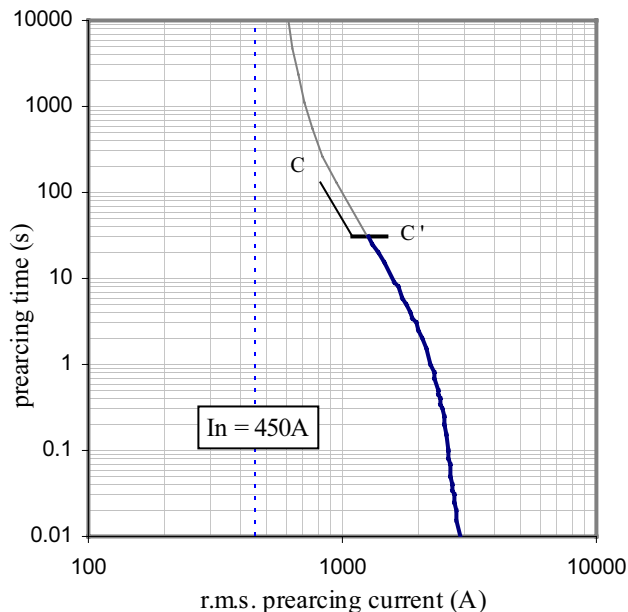

Fig.2 TCC for a typical 450A semiconductor fuse

The boundary C-C' shown on Fig.2 indicates that the fuse will safely interrupt currents at times below this limit. The fuse must **not** be applied to interrupt current levels which produce melting times longer than this limiting boundary. Sustained overloads which persist for longer times may result in failure of the fuse, and must be cleared by other means. There is a limit to how long a *temporary* overload can be tolerated by the fuse. This limit is shown by sloping part of the C-C' boundary. (New style gR class fuses do not have a C-C' limit, and can be used for overload protection.)

5. Adjusting the fuse rated current to allow for real-world working conditions

Ambient temperature correction coefficient A_I

Fuse current ratings are established by standard type tests with a reference ambient air temperature (θ_0) of 25°C or 30°C. For most power electronic applications the ambient temperature is higher than this, usually in the range 40-65°C, and the fuse must be “de-rated.” The temperature rise of the fuse depends upon the internal power generation, which is a function of the square of the current. For an ambient temperature θ the current rating must be multiplied by a de-rating coefficient A_I given by

$$A_I = \sqrt{\frac{a - \theta}{a - \theta_0}}$$

where a is the maximum allowable fuse temperature (typically 130-150°C).

Forced cooling correction coefficient B_v

If forced air is used to cool the fuse in service, the continuous current rating of the fuse may be increased, by multiplying the rated current by a coefficient, B_v . The value of the correction coefficient used by Mersen is shown in Fig.3. B_v increases linearly with air speed up to 5 m/s. Further increase in air speed does not improve the fuse cooling. The limiting value (B_l) is typically 1.25, but values higher than this are possible for fuse designs which have been optimized for cooling.

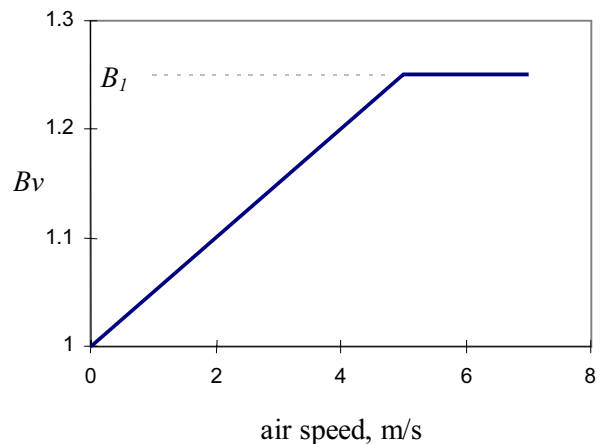

Fig.3 Correction coefficient B_v vs. air speed

Terminal conductor size coefficient C_I

In the real world, the fuse may be used with cable/bus sizes which are smaller than those used in the standard type test conducted in the lab. Since heat is conducted away from the fuse through the connection between the fuse terminals and the cable/bus, the effect of using smaller cable/bus sizes reduces the cooling and causes the fuse operating temperature to increase. Furthermore the fuse is usually located in an enclosure and its temperature may be influenced by other nearby heat-generating components. To account for these effects, Mersen uses a multiplying coefficient, C_I , to reduce the current rating of the fuse. C_I varies with fuse design configuration and is typically in the range 0.8-1.0. However, more heat can be conducted away from the fuse if the fuse terminals are liquid-cooled, and values of C_I greater than 1.0 can be used. Typical values of C_I for several types of Mersen fuse are given in the Appendix.

High-frequency effect coefficient C_{PE}

If the fuse current contains significant high frequency components, (above about 1kHz), the current distribution within the fuse changes, due to skin and proximity effects. This is due to electromagnetic field interactions, and depends upon the position of the fuse relative to the return conductor or other current-carrying conductors. An unequal sharing of current between the fuse elements is produced, which results in additional heating.

f (Hz)	C_{PE}
0 < f ≤ 100	1.0
100 < f ≤ 500	0.95
500 < f ≤ 1500	0.9
1500 < f ≤ 5000	0.8
5000 < f ≤ 10000	0.7
10000 < f ≤ 20000	0.6

Table 1 gives the de-rating coefficient C_{PE} which should be used if the fundamental component of fuse current is in the frequency range shown. For the more common case, the current waveshape contains a mixture of harmonic components and the reduction in current rating will not be so great.

Table 1. Frequency derating coefficient C_{PE}

In an application the total r.m.s. current including harmonics must be used as the basis for fuse selection. If the total harmonic content is more than 15% of the fundamental, contact Mersen Technical Services.

Current-variation coefficient A'_2

In a real-world application the r.m.s. current through the fuse is not constant, but varies depending on the nature of the load, and its duty cycle when the equipment is in operation. In addition the power conversion equipment may be switched on and off from time to time, for example during the night time. The heating and cooling of the fuse elements due to this variable loading produces expansion and contraction (thermal straining) of the fuse elements, which can cause mechanical fatigue and premature nuisance opening of the fuse. This condition is of particular importance for semiconductor fuses, which have very small notch zones on the elements in order to obtain the required high speed of operation. Variable loading causes temperature fluctuations ($\Delta\theta$) in these notch zones. It is essential to ensure that semiconductor fuses are adequately sized, to cope with the temperature fluctuations and resulting thermal strains produced in service.

Variations in the load current and duty cycle are taken into account by using a de-rating coefficient A'_2 . Loads are classified as either *continuous*, or *cyclic*, as defined below.

(a) continuous loads

Continuous means that the load current is steady when the equipment is in operation, and there are no overloads. Appropriate values for A'_2 are given in Table 2.

Working conditions	A'_2
A few stops per year (e.g. aluminum rectifier plant).	0.95
1 stop per day (e.g. overnight stop)	0.90
up to 12 stops per day	0.80

Table 2. De-rating coefficient for continuous loads (A'_2)

(b) cyclic loads

Cyclic means that the load current is variable, with a repetitive cyclic nature. In this case, the value of A'_2 may be lower than the values given in Table 2, and depends upon the nature of the cycle. For a cycle with long duration, for example 1/2 hour ON followed by 1/2 hour OFF, the fuse cools down almost completely during the OFF period, resulting in a large element temperature fluctuation $\Delta\theta$, and A'_2 must be 0.6 or lower. Please contact Mersen Technical Services for information on the value of A'_2 which needs to be used in these circumstances.

If the cycle contains **overloads** in excess of I_n it is also necessary to check the magnitude of the overload current in relation to the melting time-current characteristic of the fuse. See section 6 for further details.

Fuses connected in parallel (by the user)

In North America, the Electric Codes do not permit the paralleling of overcurrent protection devices in the field, although paralleling is permissible in a factory-built assembly. When two fuses are connected in parallel it is necessary to ensure that they share the current equally, by making the connections to the terminals symmetrical and of equal impedance. A de-rating factor of 0.9 may be necessary, depending upon the fuse type and the installation. (In some cases the voltage rating must also be reduced by 10-15% for certain fuse designs).

Please contact Mersen Technical Services when considering connecting fuses in parallel.

Combining the factors

For a single fuse with a nominal current rating I_n the maximum r.m.s. continuous current allowable in a real-world application is given by the expression

$$I_n' = I_n \times A_I \times B_V \times C_I \times C_{PE} \times A'_2$$

This is illustrated in the following simple example.

Example 1

A 900A fuse has the following data, which is given in published literature :

$$a = 130 \text{ }^\circ\text{C} \qquad \theta_0 = 30 \text{ }^\circ\text{C} \qquad C_I = 0.85 \qquad B_I = 1.25$$

What is the maximum allowable continuous current for the fuse under the following conditions of use?

ambient temperature = 55 °C

forced air cooling with $v = 2$ m/s

frequency = 1000 Hz

continuous operation with one overnight stop per day

$$A_I = \sqrt{\frac{130 - 55}{130 - 30}} = 0.866 \qquad B_v = 1 + (B_I - 1) * (2/5) = 1.1$$

From Table 1, $C_{PE} = 0.90$ and from Table 2, $A'_2 = 0.90$. The adjusted rating is then

$$I_n' = I_n \times A_I \times B_v \times C_I \times C_{PE} \times A'_2$$

$$I_n' = 900 \times 0.866 \times 1.1 \times 0.85 \times 0.90 \times 0.90 = 590.3A$$

Note that this is considerably lower than the nominal value.

These coefficients are used for routine applications. For unusual applications a more detailed study of thermal, high frequency, and other effects may be required. Please contact Mersen Technical Services for guidance.

6. Estimation of fuse life under cyclic overloads

Section 2 described the use of the factor A'_2 , which is applied to the continuous current rating of the fuse to allow for the effect of cyclic or non-continuous currents. If the duty cycle contains "overloads" (periods when the current is in excess of the fuse current rating), it is necessary to consider their magnitude and duration, in relation to the time-current characteristic of the fuse. Consider the simple ON/OFF wave shown in Fig.4.

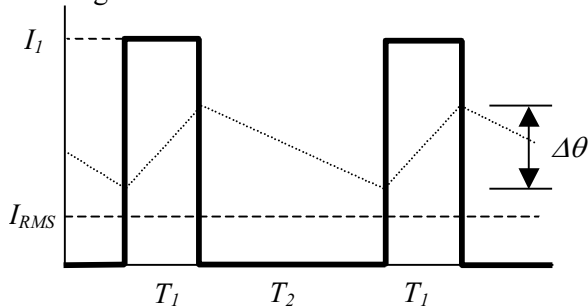

(a) duty cycle & temperature excursions

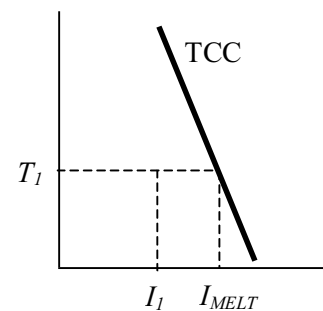

(b) comparison with fuse melting curve

Fig. 4 Cyclic overload

In Fig.4(a) the r.m.s. current I_{RMS} is very much lower than the ON current I_1 . A fuse selected simply on the basis of I_{RMS} would be much too small for this application. It is necessary to ensure that the melting time-current characteristic is well above the (I_1, T_1) point. This point is illustrated in Fig.4(b).

Coefficient B'_2

A simple method of ensuring that the fuse is large enough to withstand the cyclic overload is to require that the ON current I_1 does not exceed a certain fraction B'_2 of the current which would cause the fuse to melt in the time T_1 , i.e.

$$I_1 \leq B'_2 I_{MELT}$$

In modern applications the fuse may need to withstand several million cycles, and the value of B'_2 depends on the number of cycles N . Typical values of B'_2 as a function of the number of cycles are given in Table 3.

B'_2	N
0.31	10^6
0.35	10^5
0.45	10^4
0.50	4000
0.55	2000

Table 3. Number of cycles vs. B'_2 (typical)

The B'_2 method is suitable for hand calculation, for simple ON/OFF cycles.

The $\Delta\theta$ method

It is also possible to ensure that the fuse will give satisfactory life with cyclic overloads by estimating the peak-to-peak temperature excursions of the fuse elements produced by the load current. This method has the advantage that it can be applied to complex load cycles.

The life of a fuse under cyclic loading is determined by :

- (a) The highest peak-to-peak temperature excursion ($\Delta\theta$) of the notches in the fuse element. As $\Delta\theta$ increases, the peak-to-peak thermal strain increases, which in turn reduces the notch life. For a given material and element design, the endurance in cycles depends upon the thermal strain according to laws governing mechanical fatigue.
- (b) The average notch temperature. As the average notch temperature increases, the resistance to mechanical fatigue decreases, which results in a reduction in notch life.

Consider the simple ON/OFF cycle shown in Fig.4. The cycle gives rise to a peak-to-peak temperature fluctuation $\Delta\theta$ as shown by the dotted line.

The average notch temperature is related to the r.m.s. value of the current, integrated over the whole load cycle, (compared to the fuse rated current I_n) and depends on the ratio

$$puRMS = I_{RMS}/I_n$$

Combining these relationships with the Manson-Coffin law of mechanical fatigue gives the life of the fuse (mean number of cycles to failure N) as the power-law

$$N = \frac{K_N}{(\Delta\theta)^x (puRMS)^y}$$

Estimation of $\Delta\theta$ for a given duty cycle requires a knowledge of the transient thermal response of the fuse. This information can be extracted from the time-current characteristic, from which a transient thermal model can be constructed. Tests on fuses with various currents and duty cycles enable the constants K_N , x and y to be determined. K_N is a constant which depends upon the mechanical design of the fuse. The life is strongly dependent upon $\Delta\theta$ but the dependence on the r.m.s. level is much weaker.

For applications with complex duty cycles with several time periods at different current levels, it is necessary to estimate all the peaks and troughs of notch temperature within the cycle and count the number of stress reversals. For a cycle with M blocks of current there is a maximum of $M/2$ such reversals, and each reversal produces a fluctuation $\Delta\theta$ which contributes to the fatigue process. The life in cycles may then be estimated from

$$N = \frac{K_N}{(\Delta\theta_1^x + \Delta\theta_2^x + \Delta\theta_3^x + \dots) (puRMS)^y}$$

The $\Delta\theta$ method requires advanced numerical analysis methods and a digital computer. It is the method built in to the Select-A-Fuse / PE software (see section 18).

Selection of the correct fuse for applications with repetitive cyclic overloads is a complex procedure. Please contact Mersen Technical Services for assistance.

7. Occasional (non-repetitive) overload coefficient $C_{f\beta}$

Another overload condition to be considered is the single (non-repetitive) pulsed overload, or "occasional" overload. Such a situation occurs only a few times during the service life of a fuse, and would apply for example when the fuse has to ride through a fault which is cleared by a downstream overcurrent protection device. The objective is to ensure that the peak element temperature is below a level which would cause damage to the element notches.

In this case the allowable pulse current is significantly higher than is the case for repetitive overloads, and is given by

$$I_1 \leq C_{f\beta} I_{MELT}$$

The coefficient $C_{f\beta}$ is typically 0.75.

8. Short-circuit currents

The r.m.s. value of the **steady-state** short-circuit current which would flow in the circuit if there were no fuse protection is called the prospective current (IEC) or the available short-circuit current (North America).

In an a.c. circuit, the transient short-circuit current is given by

$$i = \sqrt{2} I \left\{ \sin(\omega t + \theta - \phi) - \sin(\theta - \phi) e^{-\omega t / \tan \phi} \right\}$$

where I is the r.m.s. prospective (available) short-circuit current

ω is the supply angular frequency ($= 2\pi f$)

θ is the electrical angle (point on the source voltage wave) at which the short-circuit begins

ϕ is the power-factor angle of the circuit impedance ($= \tan^{-1} \omega L/R$)

The first term in the above expression is the steady-state a.c. short-circuit current, while the second term is an exponentially-decaying transient d.c. component.

If the short-circuit occurs at an instant when $\theta = \phi$ the transient component is zero, and the short-circuit current will be a symmetric sine-wave (see Fig.5). The peak value is 1.414 ($\sqrt{2}$) times the r.m.s. prospective (available) current.

If $\theta \neq \phi$ the short-circuit current will have an asymmetrical waveform with an exponentially-decaying d.c. component (see Fig.5). The maximum value of the first asymmetrical peak current is obtained if the circuit is closed at the voltage zero ($\theta = 0$). It can reach 2.828 ($2\sqrt{2}$) times the r.m.s. symmetrical current in a purely inductive circuit, or about 2.5 times in a circuit with an X/R ratio of 10:1.

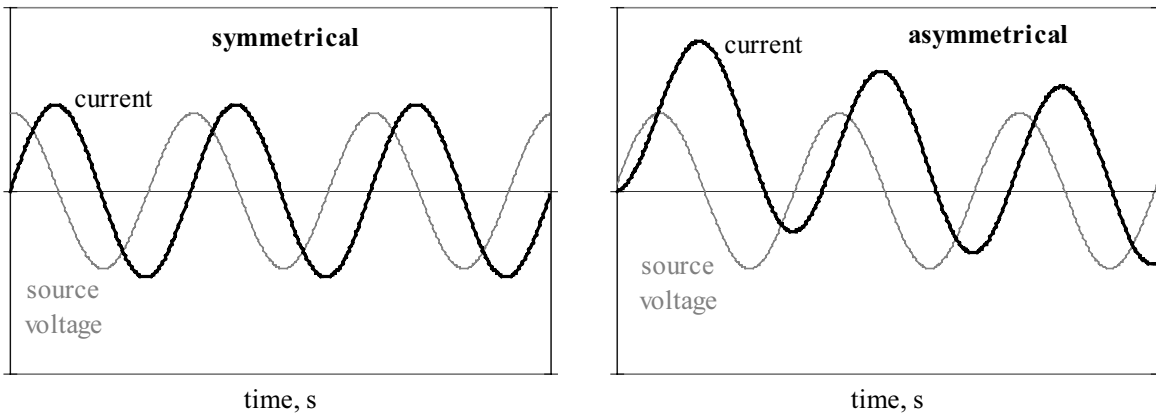

Fig.5 Symmetrical and asymmetrical short-circuit currents in an a.c. system

For a fault in a d.c. circuit the prospective (available) short circuit current is the final constant value V_{DC}/R , where V_{DC} is the source voltage and R is the resistance of the circuit. After a fault occurs, the current in the circuit increases exponentially, as shown in Fig.6, with a circuit time-constant L/R , where L is the circuit inductance.

In this case the instantaneous short-circuit current is given by

$$i = I \left\{ 1 - e^{-Rt/L} \right\}$$

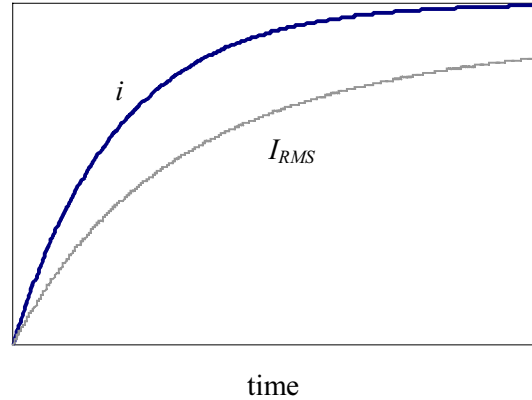

Fig.6 Short-circuit current in a d.c. system

where $I = V_{DC}/R$. The heating effect of the fault current depends upon its r.m.s. value, which is given by

$$I_{RMS} = I \sqrt{1 + \frac{2e^{-n}}{n} - \frac{e^{-2n}}{2n} - \frac{3}{2n}}$$

where $n = t/T$ and $T = L/R$ is the circuit time constant. The variation of I_{RMS} with time is also shown in Fig.6.

9. Current-limiting operation

An important advantage of the current-limiting fuse is its ability to break high fault currents rapidly, which limits the peak current flowing in the circuit, and consequently limits the let-through I^2t . Fig.7 illustrates the operation of a fuse interrupting a short-circuit fault current in an a.c. circuit. During the prearcing (melting) period the current closely follows the prospective (available) current wave and the voltage drop across the fuse is quite low. When the fuse element melts and arcing begins, the voltage across the fuse increases rapidly and the current is forced to zero well before the natural zero crossing of the prospective (available) current wave. For clarity the degree of current limitation shown in Fig.7 is low. In actuality, a typical 200A semiconductor fuse, when subjected to a prospective (available) current of 230kA peak, can limit the peak current to about 8kA, reducing the stresses on the circuit by a factor of $(8/230)^2$, or to 0.12% of the level without fuse protection.

The current-limiting behavior of fuses can be explained by reference to the equivalent circuit, which shows a fuse in a circuit under a short-circuit fault condition. Application of Kirchhoff's Voltage Law gives

$$V_S(t) = Ri + L \frac{di}{dt} + v_F$$

Rearranging this to give the rate-of-change of current

$$\frac{di}{dt} = \frac{V_S(t) - Ri - v_F}{L}$$

During the prearcing (melting) period the fuse voltage is almost zero and may be neglected, so when $V_s(t)$ is positive, the circuit current grows as shown, with $di/dt \approx V_s(t)/L$. When arcing begins, v_F increases rapidly, and if $v_F > V_s(t) - Ri$, the rate-of-change of current becomes negative, and the current is "forced" down towards zero.

The presence of the inductance in the circuit prevents the current from changing instantaneously. At the instant the fuse changes its state from the prearcing (melting or low-resistance) state to the arcing (high-resistance) state, the current stays almost constant, and the voltage developed across the fuse (arc voltage) increases rapidly.

The higher the arc voltage, the more rapidly the current will be driven to zero during the arcing period. If the design objective for semiconductor fuses is to minimize the let-through I^2t , the fuse must be designed to generate a high arc voltage. However there is a practical limit to the magnitude of arc voltage, since in a power electronic circuit, diodes, thyristors and other semiconductor components can experience this arc voltage, in the non-conducting state. In general the peak arc voltage must not exceed the peak inverse voltage withstand capability of the associated semiconductor devices.

Note that the fuse current waveform has a roughly triangular shape, and the total time to clear the fault is the sum of the prearcing time and the arcing time. This is illustrated in Fig.8.

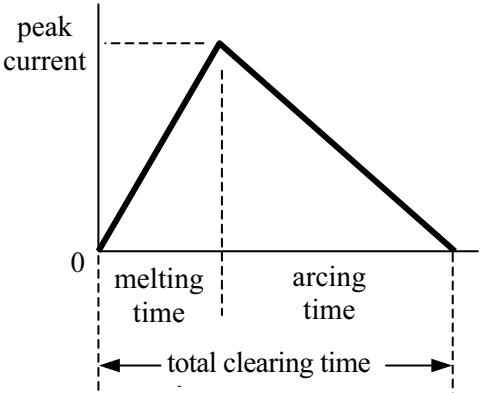

Fig.8 Approximate current wavelshape for a current-limiting fuse

Total clearing time = melting time + arcing time

For this wavelshape the total let-through I^2t is

$$\frac{I_{peak}^2 T_{total}}{3}$$

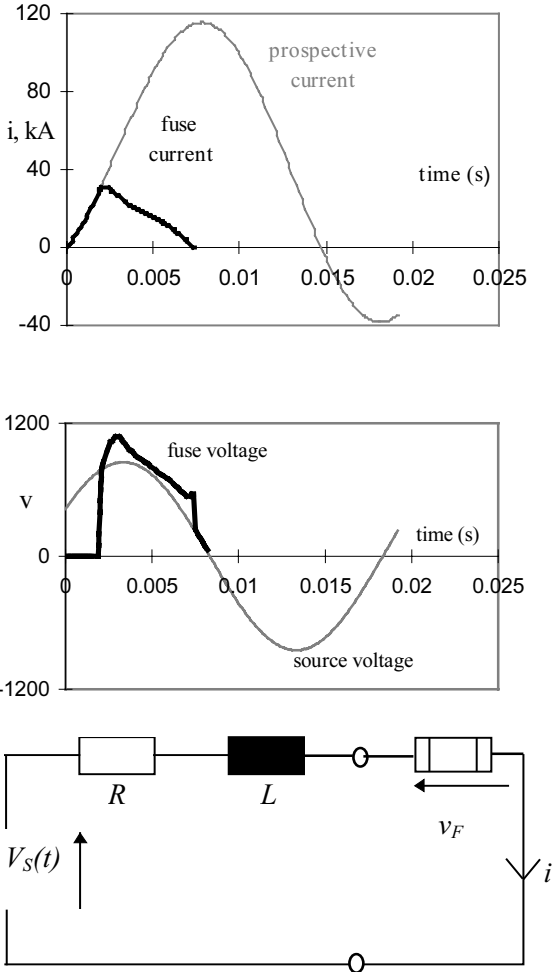

Fig.7 Limitation of peak current and I^2t

Quartz filler

If the fuse element is surrounded by a gas such as air, the arc channel is not contained and is free to expand radially. The arc resistance and hence its voltage is, very roughly, inversely proportional to the cross-sectional area of the arc channel, and therefore the arc voltage produced is too low to achieve current limitation. If however the arc cross-sectional area is kept small by confining it, the arc voltage can then be kept high, and the circuit current can be limited. During interruption, the arc power is very high. If the arc were confined within a narrow tube in a ceramic block, the very high arc temperature and pressure may cause the block to shatter due to thermal shock.

Mersen semiconductor fuses use a granular medium (quartz sand) for arc-quenching. It confines the arc and at the same time allows the pressure to be relieved. Vapors can escape from the arcing region through the gaps between the grains of sand. The sand can also absorb thermal shock by slippage between grains. As arcing continues, the grains of sand in contact with the arc melt and form a glassy body known as a **fulgurite**. This process of making fulgurite absorbs energy from the arc.

Premium quality Mersen semiconductor fuses use an agglomerated “solid” sand filler, in which the individual grains of sand are bonded together to produce a type of artificial sandstone. This “solid” sand filler further enhances the control of the arcs under high short-circuit conditions. It also improves the cooling of the elements at normal currents, because the “solid” sand filler has a higher thermal conductivity.

Peak let-through currents

For current-limiting fuses the peak let-through current (or cut-off current) is a very important parameter. Fuse data is presented in the form of peak let-through (cut-off) characteristics. These characteristics are published for specified test conditions, typically AC voltage, frequency and power-factor.

Fig.9 shows a peak let-through characteristic for a typical semiconductor fuse with a current rating of about 30A. For low prospective (available) currents, the fuse takes several a.c. cycles to melt, and the highest value of current is equal to the peak current in the first half-cycle. This is $1.414I_{RMS}$ for a symmetric wave and about $2.3-2.5I_{RMS}$ for an asymmetric wave, depending upon the circuit power factor (see Fig.5). These limits are shown by the faint lines. However, above a certain level of prospective (available) current (*threshold current*), melting occurs within the first half-cycle, and current-limiting action occurs. At high prospective (available) currents the peak current is much lower than the peak prospective (available) value. For the 30A fuse shown, the peak current is limited to only 3.25kA with an available current of 100kA r.m.s.

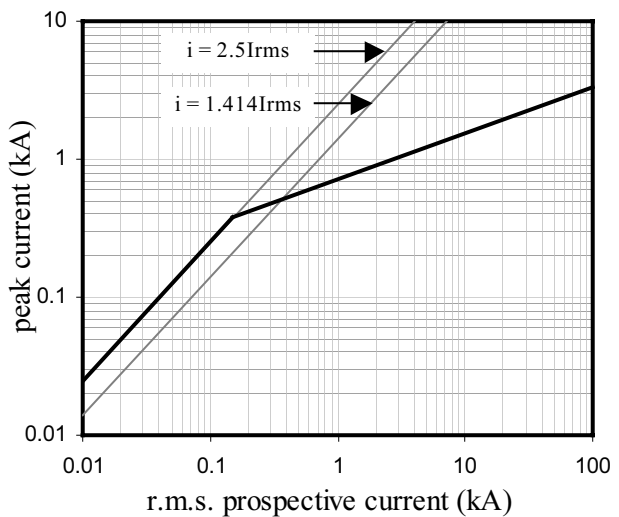

Fig.9 Peak let-through (cut-off) characteristic

For a given r.m.s. prospective (available) current, the peak let-through current varies, depending upon θ (the angle on the source voltage wave at which the short-circuit occurs). At the 100kA level the highest value is obtained with a symmetrical short-circuit wave, while in the region just above the threshold

current the asymmetrical wave gives the highest value. Published data always shows the highest possible (i.e. worst-case) value.

Melting I^2t

For high short-circuit currents, which cause melting in times of the same order as the a.c. cycle, the melting time varies greatly, depending upon whether the short-circuit current waveshape is symmetrical or asymmetrical. In these cases the time-current characteristic is of limited value, and the coordination of system protection is done using I^2t values, which are much less sensitive to the waveshape of the short-circuit current.

The lower curve in Fig.10 shows how the melting I^2t of a typical semiconductor fuse varies with the r.m.s. prospective (available) current. For very high currents, the melting I^2t is constant. This **adiabatic** region is so called because the rate of heating is so high that heat losses from the element notch zones can be neglected. For lower prospective (available) currents the melting time is longer, and heat losses from the notch zones cause the I^2t required to produce melting to increase.

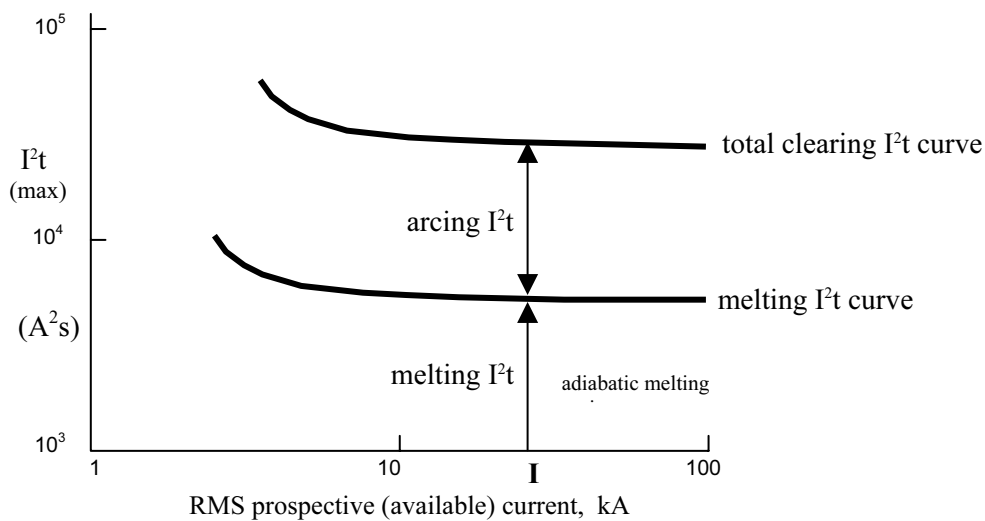

Fig.10 I^2t characteristics

Total clearing I^2t

The upper curve in Fig.10 shows the total clearing I^2t , which is given by

$$\text{Total clearing } I^2t = \text{melting } I^2t + \text{arcing } I^2t$$

In applying fuses for short-circuit protection, the total clearing I^2t of the fuse must be less than the I^2t damage level of the device or system being protected.

Published data gives the worst-case total I^2t at the fuse's rated voltage, frequency and circuit power factor. However in real-world applications, the fuses are used in systems at lower voltages. When the applied voltage is lower than the fuse's rated voltage, the current-limiting action is more effective, and the total I^2t is reduced.

The actual I^2t values which apply at voltages less than rated voltage can be determined by multiplying the published values by a correction factor K , obtained from curves such as that shown in Fig.11.

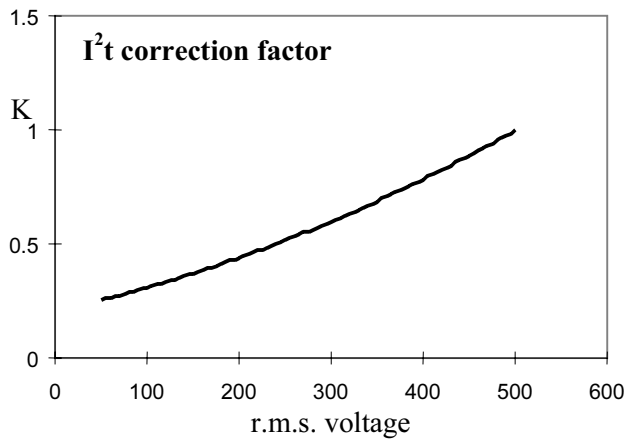

Fig.11 I^2t correction factor vs. applied voltage

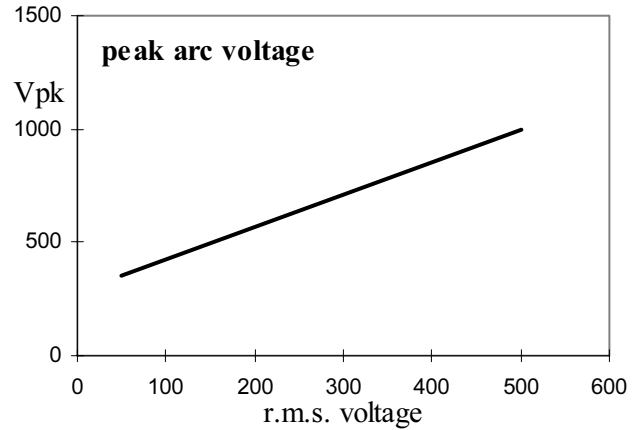

Fig.12 Peak arc voltage vs. applied voltage

Peak arc voltage

The peak arc voltage developed across the fuse during short-circuit interruption decreases as the source voltage decreases. Fig.12 shows this characteristic for a typical 500V fuse.

Rated breaking currents

A current-limiting fuse can be thought of as an **active** device during its operation. When a current limiting fuse is subjected to a short-circuit fault, it produces a high arc voltage which forces the current to zero well before the natural current zero. During the arcing period a large amount of energy is absorbed by the fuse and its filler. Fig.13 illustrates the variation of this arc energy with current for a typical semiconductor protection fuse. The **maximum breaking current** or **interrupting rating**, of this fuse is 100kA, and the fuse is type-tested at this level. However, it can be seen that there is a level of test current (about 7.5kA in Fig.13) which produces a higher energy. This is known as the “maximum energy current” or critical current, and semiconductor fuses are also certified at this test level, to insure that they can safely interrupt all possible short-circuit faults.

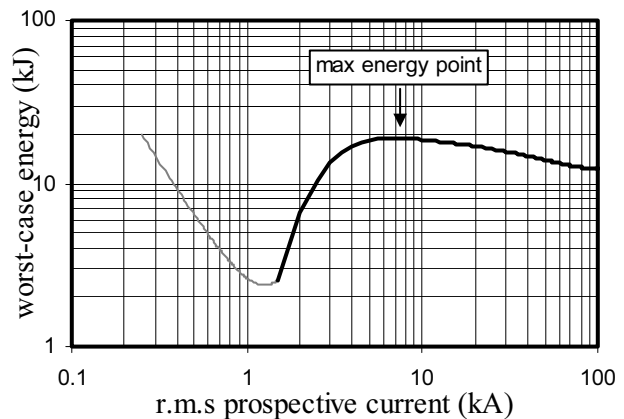

Fig.13 Energy absorbed by fuse vs. I_{RMS}

As the available current is reduced below the critical current, the energy falls, but at very low currents it begins to rise again.

This corresponds to the overload region. Most semiconductor fuses are short-circuit protective devices, and are not designed to interrupt below a certain level of current, known as the **minimum breaking current**. For a.c. faults this limiting condition corresponds to the C-C' lines on the time-current curve, as previously explained in section 4.

10. Interruption of d.c. fault currents

When a d.c. fault occurs the rate of rise (di/dt) of current is dependent on the circuit time constant (L/R). For a typical d.c. motor armature circuit, the L/R time constant is around 40ms, which yields a lower rate of rise of current (di/dt) under short circuit conditions as compared to an a.c. short circuit. With the lower di/dt , the fuse takes longer to melt compared with a.c. conditions, which also leads to a relatively long arcing time. These conditions, together with the absence of natural current zeroes, make the interruption of d.c. faults more difficult for the fuse than a.c. faults, if L/R is high. As the L/R time constant in a circuit increases, the DC voltage capability of the fuse decreases.

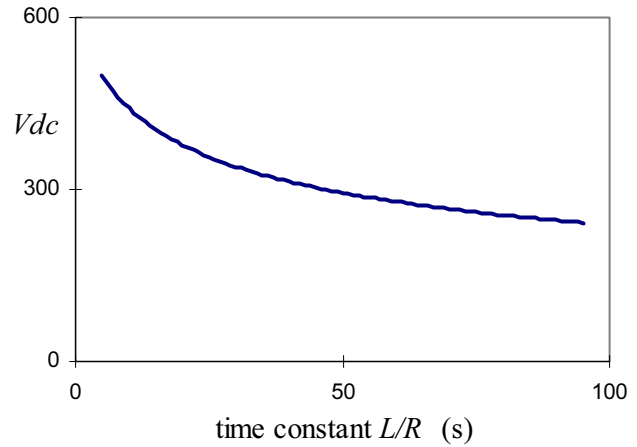

Fig.14 Effect of L/R on d.c. voltage rating

Therefore, for d.c. applications it is essential to know the value of L/R . Fig.14 shows how the d.c. voltage rating of a typical semi-conductor fuse is affected by the circuit time constant.

It is often difficult to obtain a precise value for L/R in practice. In the absence of better information, Table 4 gives some typical guideline values.

Type of equipment	Typical L/R , ms
Battery supply/capacitor bank	< 10
Bridge circuit	< 25
DC motor armature	20 - 60
DC traction systems	40 - 100
DC motor field*	1000

* It is never recommended to fuse a DC motor field circuit.

Table.4 Typical values of L/R

The arc energy produced in a d.c. circuit also varies with test current in a manner similar to that shown in Fig.13. So for a given L/R there exists a maximum breaking current, minimum breaking current, and current which gives maximum arc energy. The V_{dc} vs L/R characteristic (Fig.14) is published for the maximum fuse arc energy condition. Minimum breaking currents for d.c. applications are published separately.

11. Surge withstand of semiconductor devices

Power diodes and thyristors

Semiconductor device manufacturers publish surge current withstand in terms of a half cycle surge rating, characterized by the peak amplitude (I_{FSM}) of a single sinusoidal half-cycle pulse which the device can withstand. The duration of the test pulse (t_0) is usually 8.33 ms or 10 ms, corresponding to 60Hz or 50Hz half-cycles. Two withstand values are sometimes published : (a) with full rated voltage re-applied to the device immediately after the surge has finished and (b) with zero reappplied voltage. When fuse protection is provided, the fuse must clear the circuit current before the device is damaged. Value (b) can normally be used, because after the fuse arcs have extinguished the residual fuse resistance increases rapidly.

Often the surge withstand is given as an I^2t value (“for fusing”). The r.m.s. value I_0 for a half-sine wave is given by

$$I_0 = I_{FSM} / \sqrt{2} \quad \text{and the corresponding } I^2t \text{ value is} \quad I^2t \text{ (for fusing)} = I_0^2 t_0$$

However semiconductor devices in the ON state have very non-linear $v-i$ forward characteristics, and the instantaneous power dissipation within the device is not proportional to the square of the current. For this and other reasons the I^2t withstand of the semiconductor device is not constant, but decreases as the duration of the surge becomes shorter. Fig.15 illustrates the variation of I_{FSM} and the corresponding I^2t value for a typical thyristor.

A simple model of single-cycle surge withstand can be used to show that the withstand line can be represented by $I_0^N t_0 = \text{constant}$ where the “device exponent” N is approximately 3.0. Many device manufacturers give I_{FSM} at two different times (often 8.33 ms and 1.5 ms) and when such data is plotted in the form of Fig.15 the value of N for real devices is found to lie within the range 2.5-4.0.

In the absence of better information a device exponent of 3.0 should be used for diodes and thyristors. In other words, the device withstand is approximately a constant I^3t , and the device withstand I^2t should be adjusted by using a constant I^3t for the actual fault duration. The use of the device exponent is illustrated in the following example.

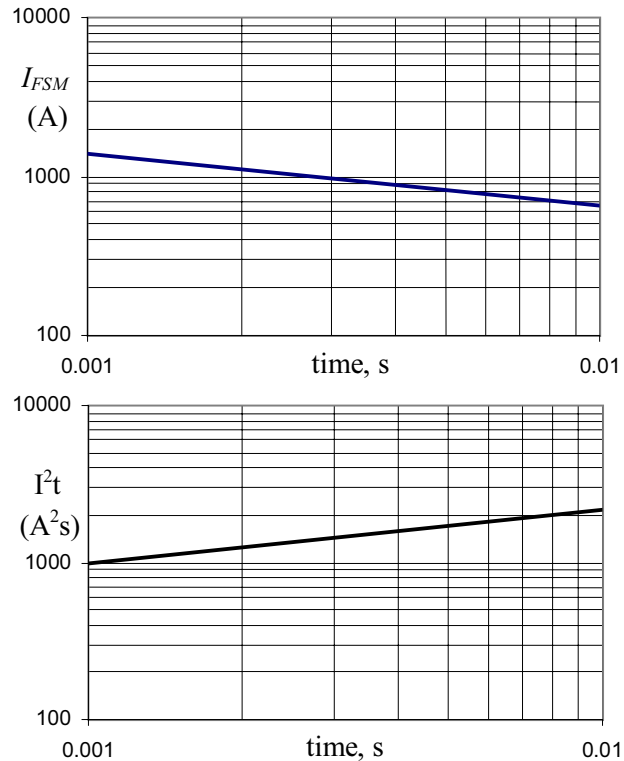

Fig.15 Variation of I_{FSM} and I^2t for a thyristor

The use of the device

Example 2

A thyristor has an I^2t for fusing of 120,000 A²s at 8.33 ms. What is the I^2t withstand for a surge of 1 ms duration ? Assume $N = 3$.

Solution

For the 8.33 ms surge the r.m.s. current $I_0 = \sqrt{\frac{120000}{0.00833}} = 3795$ A

If $I_0^3 t = K$ then $K = (3795)^3 \times 0.00833 = 4.555 \times 10^8$

At 1ms I_0 will be $(K/t)^{0.333} = (4.555 \times 10^8 / 0.001)^{0.333} = 7694$ A

so the I^2t withstand at 1ms will be $7694^2 \times 0.001 = \mathbf{59195}$ A²s.

In general the above procedure can be summarized as

$$I^2 t \text{ at time } t = I_0^2 t_0 \times \left(\frac{t}{t_0}\right)^{\frac{N-2}{N}} = I_0^2 t_0 \left(\frac{t}{t_0}\right)^{0.333} \text{ for } N = 3$$

IGBT and other power transistor circuits

When the current increases suddenly in a power transistor due to a short-circuit, the collector-emitter voltage increases immediately to a high value which gives a rapid increase in internal power dissipation and failure of the transistor. Electronic means of fault detection are often used to switch off the device very quickly. High-speed fuses are recommended in these circumstances to limit the destructive effects which occur if the electronic protection is not used or if it fails. These destructive effects include case rupture of IGBTs and melting of the emitter connections, bonding wires and other circuit conductors.

Case-rupture I^2t values for IGBTs should be used as withstand values, but these are not always available. In the absence of other data, short-circuit coordination with fuses can be done on the basis of the melting I^2t of the bonding wire. If, as is usual, copper wires are used, the melting I^2t can be estimated using

$$I^2 t = K_M A^2$$

where K_M is Meyer's constant (approximately 100,000-110,000 A²s-mm⁴ for copper) and A is the wire cross-sectional area in mm². However these values are very pessimistic. Experience shows that case rupture values are significantly higher. They can only be determined by test.

12. 3-phase controlled bridge converter

A major application of semiconductor fuses is the protection of naturally-commutated power converters, which are connected to an a.c. power system and use the sinusoidal variation of the a.c. supply to achieve commutation of current between the semiconductor devices. The basic principles for fuse protection of such converters are illustrated here by reference to the three-phase (Graetz) bridge circuit shown in Fig.16, which is the most widely used converter.

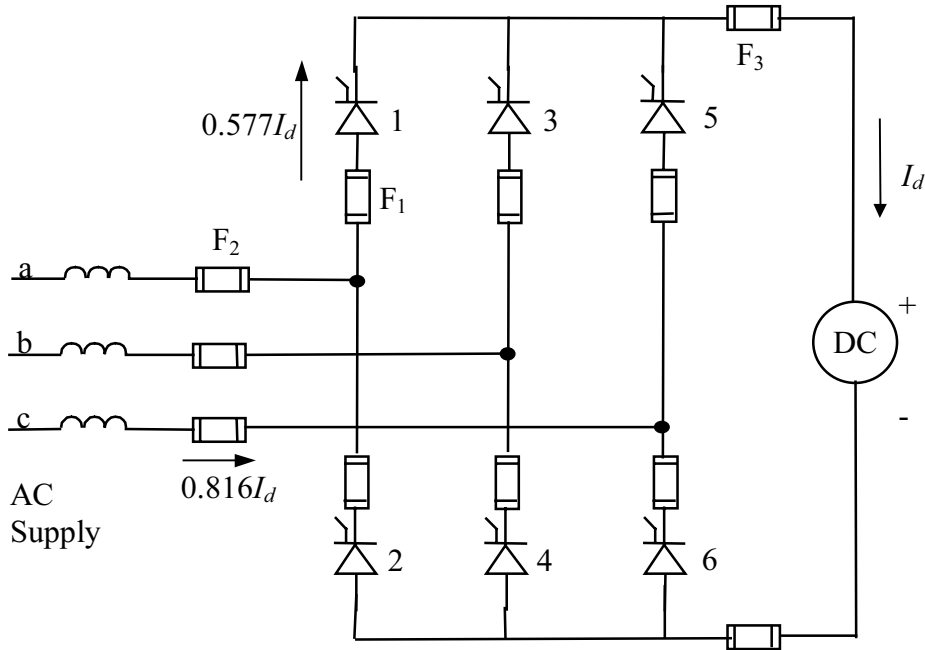

Fig.16 Three-phase controlled bridge rectifier with possible fuse locations

The anodes of the rectifying devices 1,3 and 5 are connected to the 3-phase supply, and their cathodes are connected together to form the positive pole of the d.c. output. If the devices were diodes, the one with the most positive anode would conduct at a given instant, and the output at the positive d.c. pole would be the upper envelope of the positive parts of the voltage v_A , v_B and v_C , the devices conducting in the order 1,3,5. However in a phase-controlled rectifier, commutation of current from device 1 to 3 and so on is delayed by delaying triggering of the incoming device to give the waveforms illustrated in Fig.17. Devices 2,4, and 6 are connected in the opposite direction, and their common output is connected to the negative pole of the d.c. supply. The d.c. output voltage is the difference between the upper and lower waves shown bold in Fig.17. The maximum possible average value of the d.c. output voltage (E_{d0}) is obtained with a delay angle of zero, and for this circuit is equal to 1.35 times the a.c. r.m.s. line-line voltage.

In many cases the load on the d.c. side is highly inductive, and the d.c. current may be taken to be constant. This current is switched in sequence between the parallel paths of the converter, in the sequence shown in Fig.17. If the d.c. current is I_d as shown in Fig.17, each device delivers a single unidirectional pulse of current lasting 1/3rd of the a.c. period, and the r.m.s. current in each device is $I_d/\sqrt{3} = 0.577I_d$. The current in the a.c. lines is the difference between two device currents. For phase *a* it is the difference between the currents in device 1 and device 2. This is also shown in Fig.17 and the r.m.s. value of this wave is $\sqrt{2/3} I_d = 0.816I_d$.

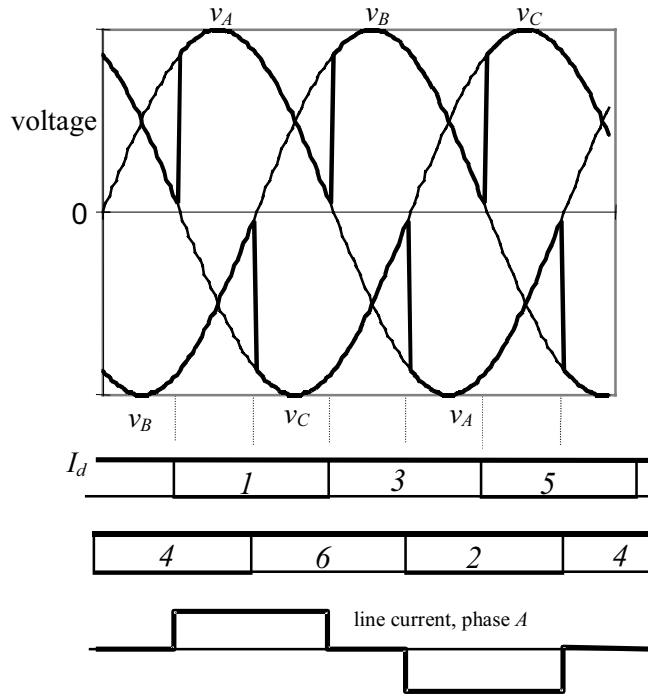

Fig.17 Three-phase bridge rectifier waveforms

Location of fuses

In Fig.16 three possible locations for fuses are shown. For rectifiers the principal choice is between F_1 and F_2 , as follows

- F_1 in the converter legs, in series with the device. This gives the best possible protection of the devices, with the smallest fuses.
- F_2 in the a.c. supply lines. This requires only 3 fuses rather than 6 and may be a more economical choice. However the line current is $\sqrt{2}$ times higher than the device current, so higher ampere rated fuses are needed, compared with fuses in location F_1 . The higher ampere rated fuses have a higher clearing I^2t , which makes it somewhat more difficult to protect the semiconductor devices. In critical cases it may not be possible to give proper protection using fuses in location F_2 .
- F_3 are on the d.c. side. These fuses are normally used only when the converter is regenerative and in conjunction with F_2 fuses. This will be discussed further in section 11.

External fault

If there is a sustained fault external to the bridge (short circuit on the d.c. side) this fault is cleared by either a high speed d.c. circuit breaker or in most cases by the fuses when there is only 1 semi-conductor per leg.

(a) **In the case of fuses in the F_1 position**, the fuses clear the fault and protect the semi-conductors. Their total clearing I^2t is less than the withstand I^2t of the device (adjusted for the fault duration as previously discussed).

(b) **In the case of fuses in the F_2 position and a high speed circuit breaker on the d.c. side**, the fault is cleared by the breaker, and the fuses must be coordinated with the breaker so they are not damaged by the current wave let through by the breaker.

(c) **In the case when F_2 and F_3 fuses are used** it is not possible to coordinate the fuses : several F_2 fuses and F_3 fuses will melt.

Internal fault

This is the most common type of fault within a converter, and is illustrated in Fig.18, in which the bold line shows the path of the normal load current at an instant when devices 3 and 6 are conducting. If in this state device 1 fails to hold off the reverse voltage and breaks down, a line-to-line short circuit across the a.c. supply lines is produced. The fault current from phase b to phase a flows through two fuses in series (either $2x F_1$ or $2x F_2$) and these must clear the faulty leg before the healthy device 3 is damaged. In order to achieve this the total clearing I^2t must be less than the withstand I^2t of the device (adjusted for the fault duration as previously discussed).

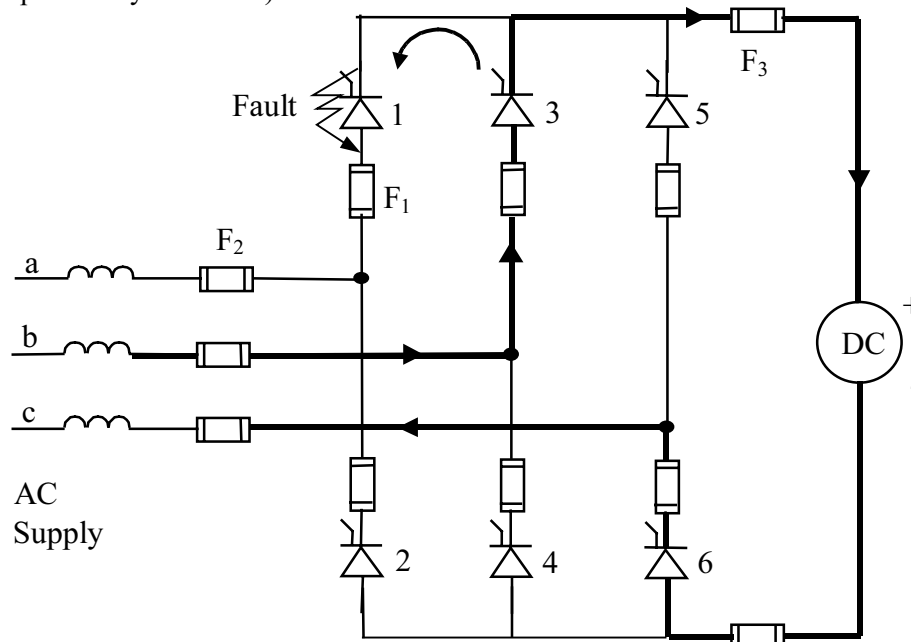

Fig.18 Internal fault

Since there are 2 fuses in series they assist each other to some extent under short circuit fault conditions, and the total I^2t is lower than would be obtained with a single fuse. If the fuses were identical, the total I^2t could be obtained by assuming equal sharing, and using the I^2t correction curve (see Fig.11) with a voltage equal to 0.5 times the a.c. line voltage. However, there is also a possible commutation from device 3 to device 5 during the fault, so that while fuse 1 is always in the fault path, fuses 3 or 5 may be in the fault path for a lesser time. Fuse 1 may melt first, followed by fuse 3 or fuse 5 after a very short time. When this happens, fuse 1 will see the full source voltage at the beginning of arcing. Therefore, the total I^2t of fuse cannot be calculated at a voltage of 0.5 times the a.c. line voltage. Also there are inevitable small differences between the fuses. Tests made by Mersen have shown that the I^2t should be calculated at 0.65 times the a.c. line voltage. However the fuses must still have an a.c. voltage rating at least equal to the a.c. line-to-line voltage. If the fuses were to operate in situations other than a short-circuit fault, the melting times would be much longer, and one fuse would melt first and have to clear the circuit on its own

against the full line voltage. Satisfactory protection of the devices may not be possible under these circumstances, but it is still essential that such faults should be cleared safely.

13. Converters with multiple parallel devices

Converters for high current applications may use several rectifying devices in parallel in each leg of the converter, as shown in Fig.19. Such circuits are commonly used for electrochemical and heavy-duty traction applications.

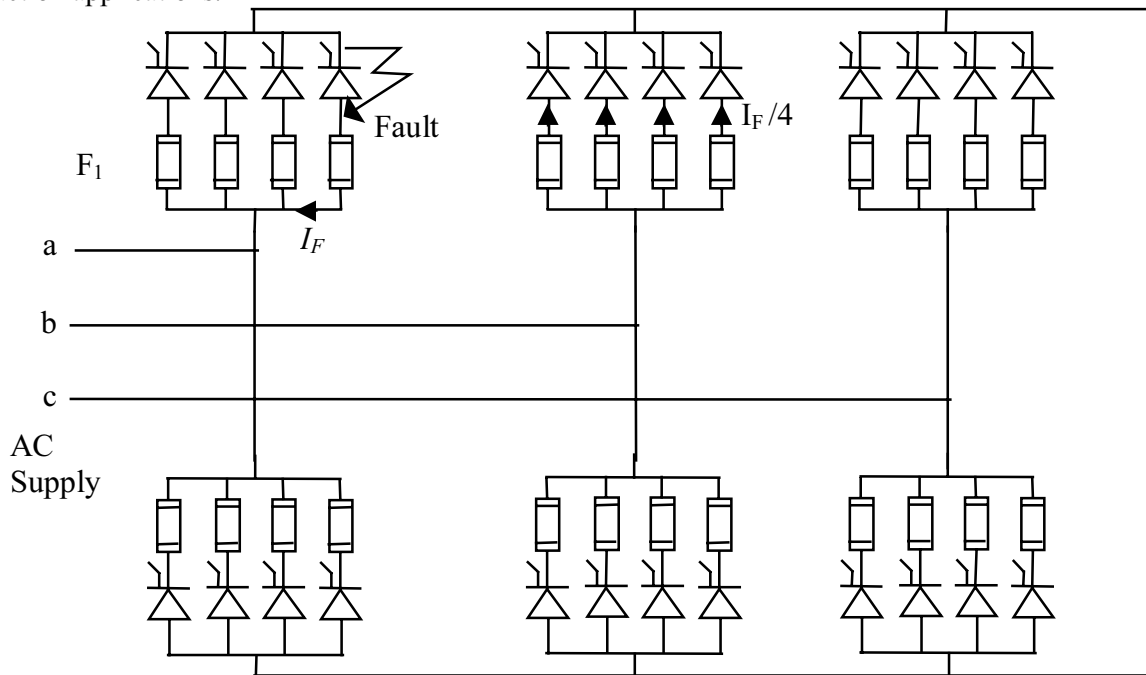

Fig.19 High current three phase bridge rectifier

In this case each device has a fuse in series with it (F_1) so that each device is protected and to ensure that if a device failure occurs, only one fuse will operate. The faulty device will be isolated, the converter will be able to continue to operate, and the faulty device and blown fuse can be replaced at some later time. There is no possibility of protecting parallel devices with fuses in the a.c. line, since the fuses would be too large. The current on the d.c. side of the converter is very high and is often controlled with a d.c. breaker. Alternatively, in very large rectifiers, a d.c. short-circuit (external fault) may be cleared by a breaker on the a.c. side (sometimes in the primary side of the supply transformer). It is often required that the fuses should survive the clearance of an external fault by a breaker without deterioration (see section 7). The general principles for fuse selection are the same as described in the previous section, but with the following additional requirements.

Device redundancy

If there are n devices in parallel per leg, the current in each fuse is I_{LEG}/n , and the required continuous current rating is based on this value. However, as previously mentioned, it is common to operate the converter for a considerable period of time after one fuse has opened. If this is the case, the fuse current will be $I_{LEG}/(n-1)$, and its continuous current rating must be based on this higher value.

Allowance for unbalance

Usually an adjustment should be made to allow for the fact that the parallel branches in the leg do not share the current equally. If this is the case, the fuse rating must be based on the calculated current through the fuse, as shown above, which is then increased by the expected imbalance. If the total current is I and an unbalance of 10% is assumed, the fuse rating should be based on leg current of $1.10 \times (I/n)$. If there is a redundancy requirement in an unbalanced system then the leg current of $1.10 \times (I/(n-1))$ should be used. (Note: In some very large power converters the unbalance can reach 60%).

Protection against device explosion

For a fault such as that shown in Fig.19 the fuse which opens is in series with a device that has failed. The fuse's first job is to clear the circuit before the faulty device explodes. In this case the total clearing I^2t of the fuse must be less than the explosion I^2t of the device. The explosion I^2t of a device is usually around 4 times the withstand I^2t for fusing (contact the device manufacturer for a precise value).

Device protection for an internal fault

In the event of an internal fault, the short-circuit current from the a.c. side flows through the fuse in series with the faulty device. It also flows through the n devices in parallel in the healthy leg of the bridge in series. The other job of the fuse in series with the faulty device is to protect the n devices in the healthy leg in series. During a fault the sharing of the current between the parallel paths is much better than the sharing of the current during normal operation. In practice the adjustment for unequal sharing of the short-circuit current between the parallel paths is typically 5 to 10%. Assuming a 5% unbalance (a realistic value when there are 4 devices in parallel as shown in Fig.19) the current in the most loaded branch of the healthy leg will be $1.05/n$ times the fault current. The total clearing I^2t of the fuse must be less than $(n/1.05)^2$ times the device withstand I^2t (adjusted for the fault duration). For large values of n this means that device protection is usually easy to achieve. (Instead of using a typical 5 to 10 % unbalance, the SAF/PE software uses the same per cent unbalance under short circuit conditions as under full load conditions, which yields a more conservative solution). Since only one fuse will operate to clear the fault, it must be rated for the full a.c. voltage (and sometimes the d.c. voltage), and no assistance from other fuses can be assumed when calculating the fuse let-through I^2t .

Inter-leg fuse selectivity

To enable uninterrupted operation of the converter after the fault and to prevent the opening of a large number of fuses, the fuse in series with the faulty device must clear the fault before any of the fuses in the healthy leg of the bridge in series reach their melting point. Assuming, as in the previous section, a 5% unbalance during the short circuit, the current in the most loaded branch of the healthy leg will be $1.05/n$ times the fault current. This an occasional overload and the C_{f3} coefficient on the current (see section 7) must be used, which becomes C_{f3}^2 for I^2t values. Then if P is the melting (prearcing) I^2t of the fuse at a time equal to its total clearing time, and T is the total clearing I^2t , it is necessary that:

$$T \times \left(\frac{1.05}{n} \right)^2 \leq C_{f3}^2 \times P$$

If n is large it is easy to meet this condition, while for $n = 1$ it is clearly impossible. Usually with $n = 3$ selectivity can be obtained, but if the converter is already operating with one device out due to a previous fault, selectivity becomes very difficult and may not be possible.

14. Regenerative loads

Inversion in line-commutated inverters

If the delay angle of the 3-phase bridge converter is increased above 90° the d.c. output voltage reverses polarity. The current through the rectifying devices remains of the same polarity and as a result the power delivered to the d.c. side becomes negative. In other words, power is being transmitted from the d.c. side to the a.c. side. This is the regenerative or inverting mode and the waveforms are shown in Fig.20. The current waveforms are drawn as before on the assumption that the d.c. current is approximately constant. In the regenerative mode, this is only possible for a sustained period if there is a source of energy in the d.c. side, e.g. a battery, generator or rotating machine with stored kinetic energy. The regenerative mode enables energy savings for example when lowering crane loads by returning energy to the a.c. system. If the converter operates in the regenerative mode certain types of fault conditions require the fuses to have an adequate d.c. interrupting capability.

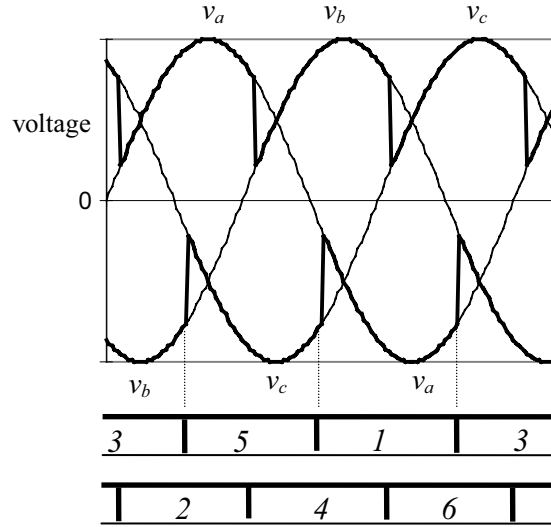

Fig.20 Converter waveforms in inverting mode

DC shoot-through fault in inverting mode

Fig.21 illustrates the d.c. shoot-through (or diametric) fault. Devices 3 and 6 are conducting normally, but the polarity of the output voltage is reversed, compared with Fig.18. If, during this period, device 5 fails to block, a d.c. short-circuit current will flow clockwise around the loop which contains devices 6 and 5.

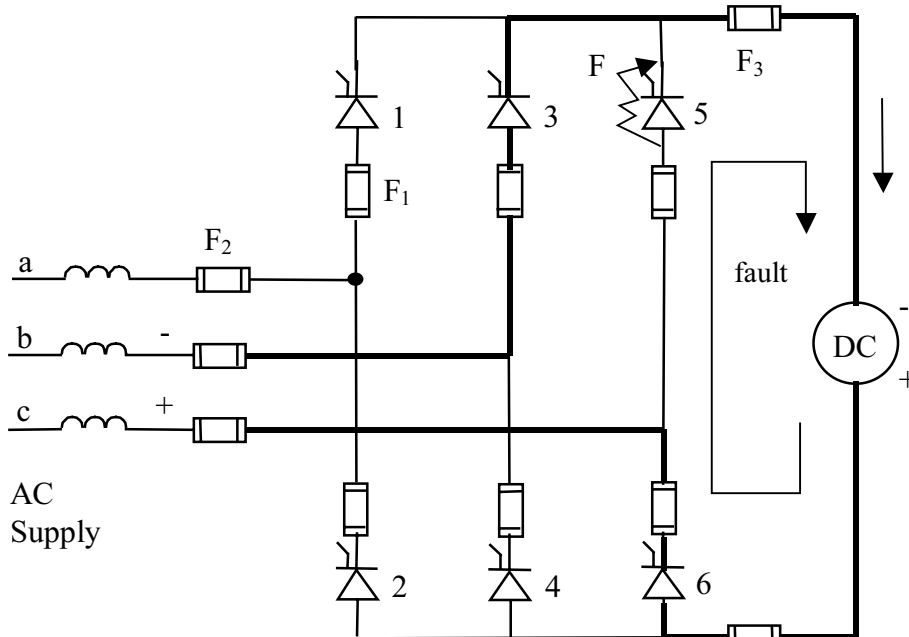

Fig.21 DC shoot-through fault in inverting mode (diametric fault)

Two possible situations can be considered

- If only F_1 fuses are installed then the d.c. fault current will be interrupted by two of these fuses acting in series. They assist each other to some extent, depending upon the melting time, which is influenced by the inductance of the fault loop.
- If fuses have been installed in the a.c. line (F_2) rather than at F_1 , it will be necessary to have d.c. side fuses F_3 installed to interrupt the d.c. fault. Mersen recommends that two F_3 fuses should be used. The d.c. fuses must be rated for the full d.c. voltage at the L/R time constant of the circuit.

Note that if a shoot-through fault occurs when in the *rectifying* mode, the d.c. fault current would be counter-clockwise around the loop containing devices 6 and 5 (see Fig.21). This is in the opposite direction to the pre-existing load current, and causes the current through the healthy device 6 to be reduced rapidly to zero, when it turns off and interrupts the fault. For this reason F_3 fuses are not needed unless the converter is regenerative.

Commutation failure (non-diametric fault)

Another important type of fault which can occur in the regenerative mode is a commutation failure (or non-diametric fault) which occurs when an incoming thyristor fails to switch on. This failure produces a combination a.c.+ d.c. fault condition in which fault current flows round a loop formed by the a.c. supply, the two previously-conducting thyristors, and the d.c. side. This is illustrated in Fig.22. In this case devices 3 and 6 were conducting normally, but then the current failed to commute from 6 to 2. The a.c. voltage applied to the loop then reverses and adds to the voltage on the d.c. side.

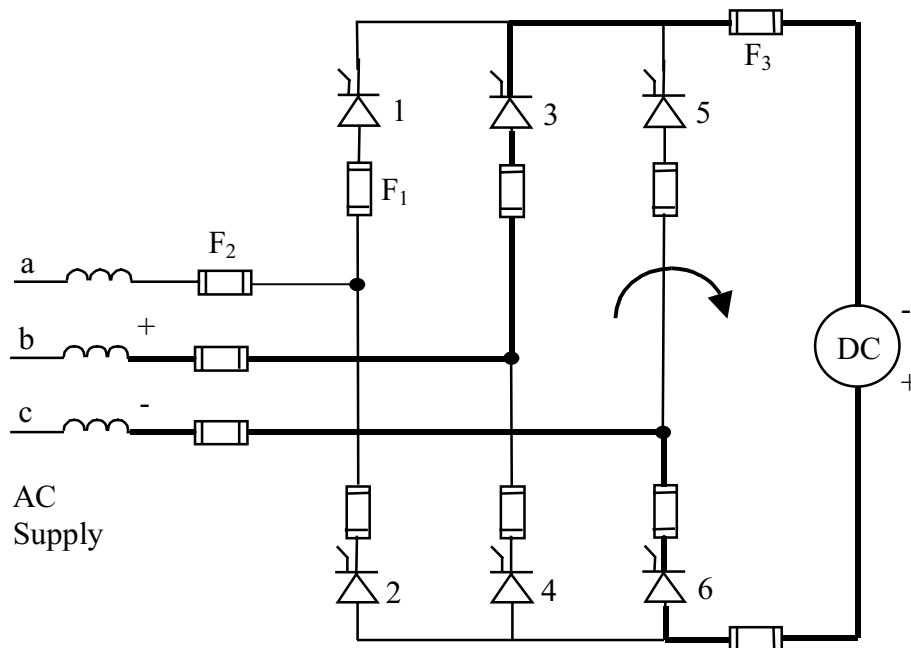

Fig.22 Commutation failure in inverting mode (non-diametric fault)

The fault current is driven around the loop with 2 fuses at F_1 or F_2 in series. The required a.c. and d.c. voltage ratings for these fuses depends on the magnitude of the fault and the extent to which the 2 fuses at F_1 or F_2 assist each other. For very large inductances on the d.c. side, the prearcing time can be long, and no assistance should be assumed.

The required fuse voltage rating in this case depends upon assumptions made about the severity of this type of fault, and the extent to which the 2 fuses in series share the breaking duty. Equipment designers have different rules for this situation. Depending upon the application the required minimum voltage ratings should lie within the following ranges :

Minimum AC voltage rating must be K_{AC} times the maximum a.c. line voltage. ($K_{AC} = 1.0$ to 1.7)

Minimum DC voltage rating must be K_{DC} times the maximum d.c. side voltage. ($K_{DC} = 0.6$ to 1.0)

Please contact Mersen Technical Services for further details. The commutation fault does not need to be considered for high power converters with multiple devices per leg. In this case all faults involving the d.c. side are cleared by a d.c. breaker and the fuses must coordinate with the breaker - the fuses need only to be rated for internal converter faults.

For d.c. faults it may not be possible to provide I^2t protection of the devices. In this case the fuses will only provide safety isolation in the event of a fault.

Anti-parallel connection

Fig.23 shows a circuit commonly used to regenerate power in d.c. drive systems, by reversing the direction of current flow, rather than reversal of polarity of the load voltage. This is achieved by using back-to-back thyristors which gives full directional control of the bridge.

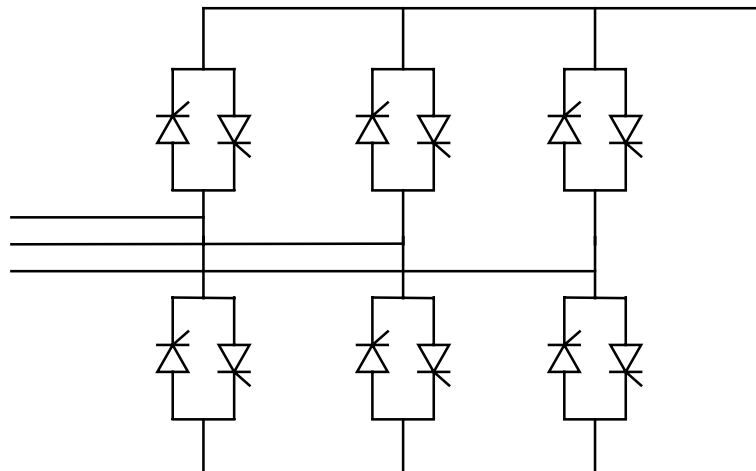

Fig.23 Reversible bridge with anti-parallel thyristors

The fuse selection rules previously given for the standard 3-phase bridge can also be used for this circuit. Similar considerations also apply to *double bridges*, in which two basic 3-phase bridges are connected in series or parallel, to give a higher voltage or current output.

15. AC controllers (soft-starters, static switches)

These circuits are used to provide a phase-controlled a.c. output from an a.c. source, and are used in soft starters or as static switches. The 3-phase circuit is shown in Fig.24. The principles of fusing are the same as for general converters, except that there are no d.c. fuse rating requirements. Fuse selection is usually made on the basis of an assumed line-to-line fault. In this case there are 2 fuses in series in the fault path, and the let-through I^2t should be calculated at 0.65 times the a.c. line voltage.

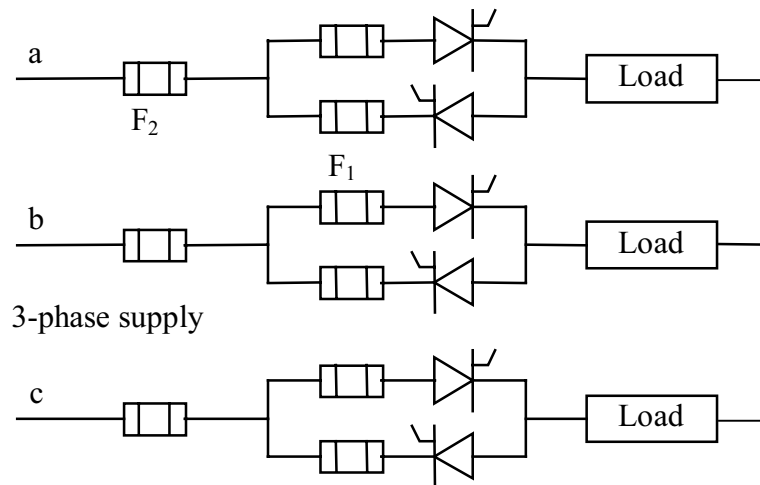

Fig.24 Three-phase a.c. soft starter or static switch

In most soft-starter applications the fuse current rating is determined by the overload produced by the starting current of the motor. Very often this overload is 300% for 10-30s and can occur several times per hour. (Sometimes the overload is as high as 450%). Fuse selection is mainly influenced by the time-current curve in the 10-30s region.

It may be desired to base fuse selection on an assumed 3-phase fault. In this case there is maximum asymmetry in one of the phases, which causes melting of the fuse in that phase before the other two. This fuse operates first and clears alone with a voltage of 0.866 times the line voltage, which will give a higher I^2t let-through.

Location of the fuses in series with the devices (F_1) gives the smallest fuses, with the best possible protection of the devices. Locating the fuses at F_2 requires only 3 fuses rather than 6 and so may be a more economical choice. However the r.m.s. line current is $\sqrt{2}$ times the device current so higher ampere rated fuses are needed at F_2 , making device protection more difficult.

16. Forced commutated inverters

The generic inverter circuit shown in Fig.25 is widely used to generate a 3-phase quasi-sine-wave a.c. output from a d.c. supply by switching. The d.c. supply may be a battery in a UPS system or the output of a controlled rectifier in a solid-state a.c. drive system. The switches may be thyristors, power transistors, IGBTs or similar devices.

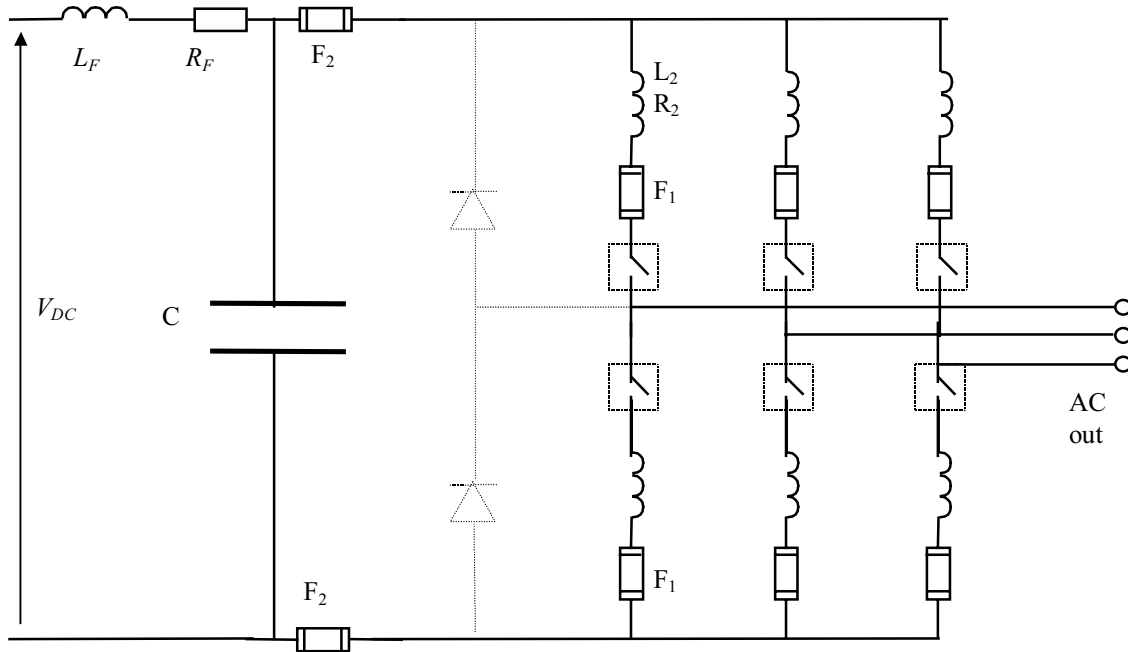

Fig.25 Generic forced-commutated inverter

Fuses may be located in series with the inverter legs (F_1) or in the d.c. input line at F_2 . The r.m.s. current at location F_2 is $\sqrt{3}$ times the current at F_1 , so smaller-sized fuses, more closely matched to the thermal rating of the devices can be used if location F_1 is chosen. In either case the rules given previously in section 2 for the required continuous current rating of the fuse must be applied.

I^2t protection is based upon the assumption of a d.c. shoot-through fault in the inverter, in which case the reservoir capacitor, C , discharges through two inverter legs in series, including resistance $2 \times R_2$ and $2 \times L_2$. The fault current waveforms are usually oscillatory, and a typical case is shown in Fig.26 which is for the case where no pump-back diodes are present (shown with dotted lines in Fig.25). As the current rises towards the first peak the capacitor voltage falls and then goes negative. The waveforms for the circuit with pump-back diodes are similar except that the diodes clip off the negative parts of the capacitor voltage wave. The fault current is the same for both locations, F_1 or F_2 .

The oscillatory component of the fault current is added to the d.c. contribution from the supply system which normally charges C . This component of current is also shown in Fig.26 (faint line). Note that after the first cycle of oscillation the fault current continues to rise steadily. The d.c. supply system often contains a filter with considerable inductance. In this case it is essential to select a fuse which will melt before the capacitor voltage goes negative. This avoids requiring the fuse to interrupt a potentially damaging d.c. follow-through current from the charging source.

Under these conditions the interruption of the fault current will be rapid (less than 10ms), and against the decreasing voltage from the discharging capacitor. This condition is similar to that which occurs when a.c. type-testing of fuses at high current (~100kA), when the circuit is closed at about 65° on the applied voltage wave. However as soon as arcing begins the voltage applied to the fuse becomes d.c. rather than oscillatory (the circuit is overdamped by the arc resistance). For these reasons choice of a fuse for inverter applications depends upon the initial maximum capacitor voltage (E_M) and also voltage across the capacitor (U_{PM}) at the start of arcing. For some fuses E_M and U_{PM} are the same but for other types U_{PM} can be lower than E_M . Fuses with a trip indicator may have lower E_M and U_{PM} values than fuses without an indicator. The Mersen publication NTSC120 gives these values for a selection of fuse types as well as curves allowing calculation of the total I^2t and other parameters. As an alternative, the let-through I^2t and clearing time can be computed using a transient model which represents the interaction between the fuse and the circuit, including the charging source. This is a complex procedure and is unsuitable for hand calculation.

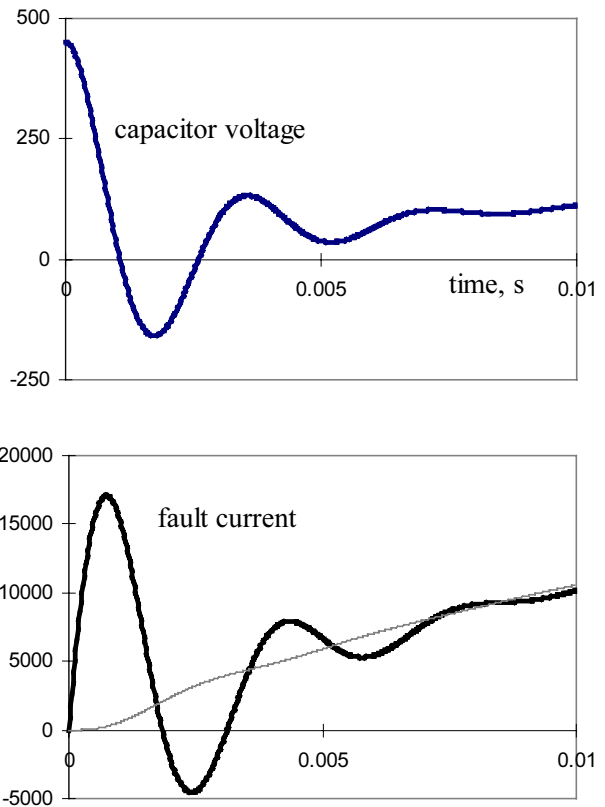

Fig.26 Short-circuit waveforms for internal fault

It is the method built in to the Select-A-Fuse for Power Electronics software. (See section 18).

When a single F_2 fuse is used it must be rated for the full d.c. voltage. If two fuses are used, they can be assumed to share the breaking duty, because the operation is normally so fast that both fuses will melt. A voltage reduction factor of 0.6 can then be used for the calculation of the I^2t . If the fuses were to operate in situations other than a perfect short-circuit fault, the melting times could be much longer, and one fuse would melt first and have to clear the circuit on its own against the full d.c. voltage. Therefore for safety reasons each fuse should be rated for full d.c. voltage. Satisfactory protection of the devices may not be possible under these circumstances, but it is essential that such faults should be cleared safely. It is recommended that the fuse selected should clear the circuit within 10ms.

Skin and proximity effects

As the frequency increases, the current in a conductor tends to shift towards the outside surface of the conductor (or group of conductors) due to the skin effect. If the return path for the current is near that conductor or conductor group, this causes an additional shift of current within the conductor, towards the return path. This is the *proximity effect*, and like skin effect, it increases with frequency. Inductance is flux linkage per ampere, and the inductance of an electric circuit may be separated into two parts. The *internal* inductance is due to the flux linkages within the conductor, while the *external* inductance is due to the flux linkage of the loop external to the conductor. As frequency increases the total inductance initially decreases because of the decrease in internal flux due to skin effect. At very high frequencies only external inductance remains.

At high-frequencies a multiplying coefficient C_{PE} must be applied to the fuse rated current, to allow for the extra heating of the fuse caused by skin and proximity effects (see section 5).

Fuse insertion inductance

Semiconductor fuses are increasingly being used to protect IGBT inverters against the effects of short-circuit faults. These circuits switch at high frequencies, typically around 10kHz. At these frequencies the switching di/dt is high, and the circuit inductance must be kept low to minimize transient over-voltages. The effect of the insertion of a fuse on the circuit inductance can be an important consideration in circuit design. The additional induction caused by the insertion of a fuse is mainly due to the modification to the circuit loop. The internal self-inductance of the fuse is negligible.

Minimizing the circuit inductance

To minimize the inductance of a circuit containing a fuse it is necessary to consider the geometry of the fuse and circuit together, to keep the area of the loop as low as possible. This may be difficult with large fuses. An excellent solution to this problem is to use two small fuses in parallel, with sufficient spacing between them to minimize magnetic field interaction, as shown in Fig.27(a). The total inductance is almost half that of one fuse because of the parallel connection. An alternative is to use a flatpack design as shown in Fig.27(b). The arrangements shown also minimize proximity effect. It should be emphasized that the fuse is only part of the loop, and a low inductance can only be achieved by considering the complete system design.

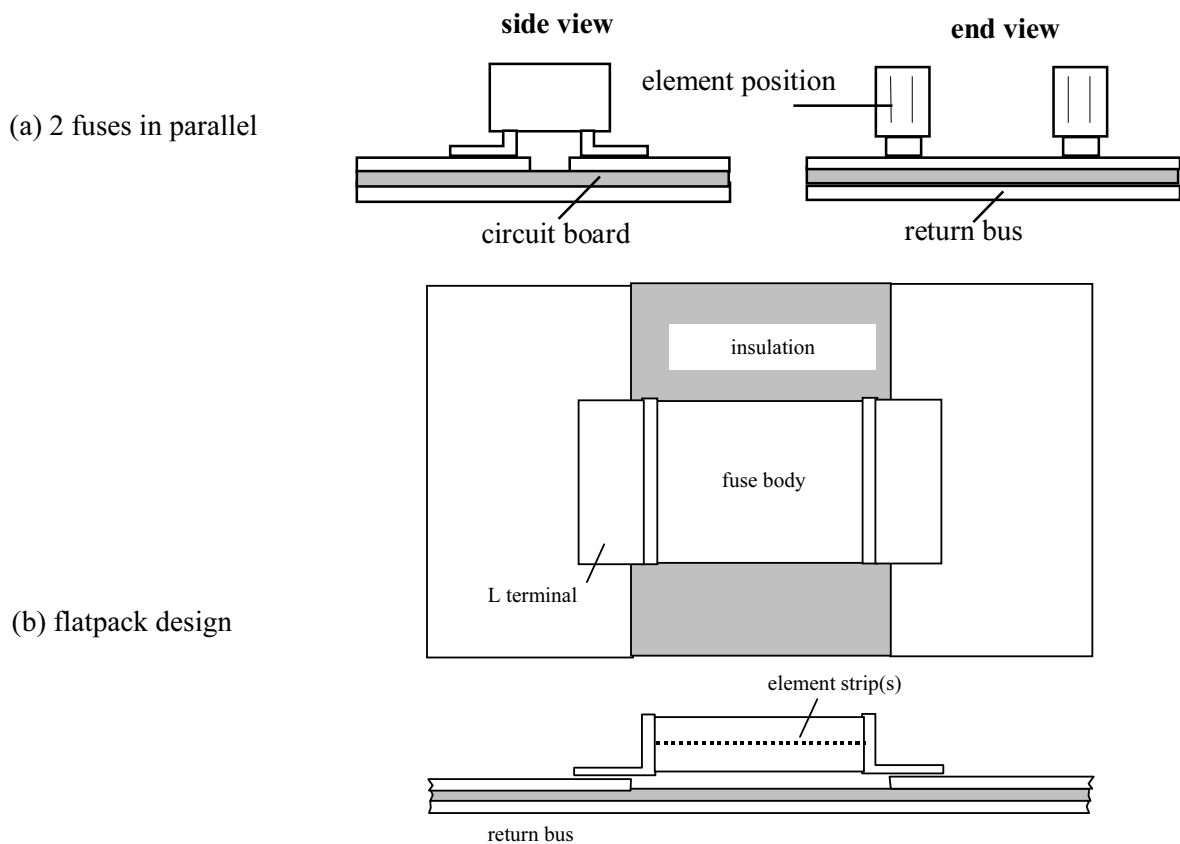

Fig.27 Reduction of insertion inductance

17. Fuse selection examples

17.1 3-phase a.c. controller

Select a suitable fuse from the Mersen square-bodied PSC range, size 30, to protect the a.c. controller shown in Fig.28. The equipment designer has indicated that the possibility of a 3-phase fault need not be considered.

System data is as follows :

Max AC line voltage	660 V
Frequency	50 Hz
Ambient temperature	55 °C
Cooling air speed	2 m/s
Load current	100 A
Short-circuit current	5 kA
Continuous load	< 12 stops per day

Occasional overload 200% for 10s

Thyristor I^2t withstand 20,000 A²s
(at 8.33 ms)

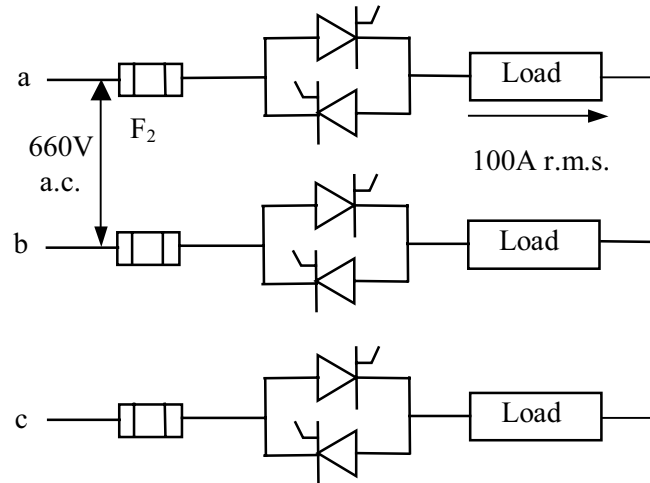

Fig.28 3-phase a.c. controller

Data for the PSC size 30 is as follows :

a	= 130
θ_0	= 30
B_1	= 1.25
C_1	= 0.85
C_{f3}	= 0.75

For continuous load with < 12 stops
per day

$A'_2 = 0.8$ (see Table 2)

First estimate the required continuous current rating

$$\text{correction for ambient temperature } A_1 = \sqrt{\frac{130 - 55}{130 - 30}} = \mathbf{0.866}$$

$$\text{correction for non-standard terminal contacts } C_1 = \mathbf{0.85}$$

$$\text{correction for forced air cooling } B_v = 1 + (1.25 - 1) * 2/5 = \mathbf{1.1}$$

$$\text{correction for load variations } A'_2 = \mathbf{0.8}$$

Since the r.m.s. fuse current is the same as the load current of 100A, we require that the adjusted fuse current rating is greater than 100A, which gives

$$I_n' = I_n \times A_1 \times B_v \times C_l \times A'_2 \geq 100.0$$

$$I_n \times 0.866 \times 0.85 \times 1.1 \times 0.8 \geq 100.0$$

This gives $I_n \geq 154.4$ A.

This fuse can be used in a.c. systems up to a maximum of 760V, which is above the requirement of the application.

Choose the next higher rating in the product series, which is 160A. To confirm that this fuse will protect the thyristor, the let-through I^2t will need to be evaluated at a voltage of $0.65 \times 660 = 429$ V (assuming the selection is based on a line-line fault condition). Published data for this fuse is as follows :

Total clearing I^2t at 700V	9400 A ² s
Peak let-through current at 5kA	2.428 kA
I^2t correction factor at 429V	0.560

So the total clearing I^2t in the application will be $0.560 \times 9400 = 5\ 264$ A²s.

Assuming a triangular short-circuit current waveshape, the fault duration can be found from

$$I^2t = \frac{I_{peak}^2 T_{FAULT}}{3}$$

i.e. $5264 = 2428 \times 2428 \times T_{FAULT} / 3$

which gives

$$T_{FAULT} = 2.68 \text{ ms}$$

Assuming a constant I^2t for the thyristor, the thyristor withstand at 2.68 ms is (see p19)

$$I^2t = I_0^2 t_0 \left(\frac{t}{t_0} \right)^{0.333} = 20,000 \left(\frac{2.68}{10.0} \right)^{0.333} = 12\ 895 \text{ A}^2\text{s}$$

This is much greater than the fuse total clearing I^2t , so the fuse will protect the thyristor.

Finally check the occasional overload requirement. Referring to the 160A fuse's time-current characteristic, we find that $I_{MELT} = 392.8$ A at the 10s point. The maximum allowable overload current is $C_{\beta} \times 392.8 = 0.75 \times 392.8 = 294.6$ A for 10s. This is acceptable as it is greater than the actual overload current, which is 200% of 100A = 200A for 10s.

Hence, the PSC size 30 160A fuse would be suitable for this application.

(Note that if the equipment designer had specified that a 3-phase fault must be considered, the fuse I^2t would need to be evaluated at $0.866 \times 660 = 572$ V).

17.3 Regenerative 3-phase bridge

Find a fuse from the Mersen round-bodied A50QS or A70QS types which will protect the bridge shown in Fig.29, when fitted in location F₁.

System data :

Max AC line voltage	460 V, 60Hz
Ambient temperature	45 °C
Current loading	250 A d.c.
AC s.c. current	10 kA
DC working voltage	500 V (regenerative load)
DC load time constant	30ms
Occasional overload	500% for 0.1s
Repetitive cyclic load	141.4% for 1 hour, then 1 hour off.
Natural cooling	
Semiconductor devices	I ² t withstand 68kA ² s at 8.33 ms; Peak inverse voltage 1.5kV

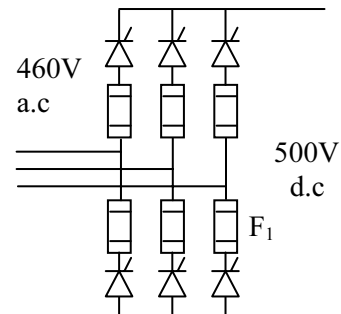

Fig.29 3-phase bridge

The fuses must have an a.c. voltage rating of at least 460V and a d.c. voltage rating with $L/R = 30$ ms of at least 500V. Referring to the product datasheets these values are :

	V_{AC}	V_{DC} at $L/R=30ms$
A50QS	500	464
A70QS	700	635

The d.c. voltage rating of the A50QS is too low, so this type cannot be used. The A70QS however may be suitable. The thermal coefficients for this fuse type are

a	= 150	For a 1hour ON/OFF cycle the fuse will cool down completely between cycles so the lowest value of A'_2 must be used (see section 5)
θ_0	= 25	
B_1	= 1.25	
C_1	= 0.85	
C_{β}	= 0.75	

First estimate the required continuous current rating

$$\text{correction for ambient temperature } A_1 = \sqrt{\frac{150 - 45}{150 - 25}} = \mathbf{0.917}$$

$$\text{correction for non-standard terminal contacts } C_1 = \mathbf{0.85}$$

$$\text{correction for load variations } A'_2 = \mathbf{0.6}$$

For the 3-phase bridge the r.m.s. current in the leg at F_1 is 0.577 times the average d.c. current, i.e. $0.577 \times 250 = \mathbf{144.25A}$.

$$I_n' = I_n \times A_1 \times C_1 \times A_2' \geq \mathbf{144.25}$$

$$I_n \times \mathbf{0.917} \times \mathbf{0.85} \times \mathbf{0.6} \geq \mathbf{144.25}$$

This gives $I_n \geq 308.4$ A. Choose the next higher size in the series, which is 350A. To check now that this fuse will protect the thyristor, the let-through I^2t will be evaluated at a voltage of $0.65 \times 460 = 299$ V. Referring to the product datasheet for the A70QS350 we obtain :

Total clearing I^2t at 700V	72000 A ² s
Peak let-through current at 10kA	6.705 kA
I^2t correction factor at 299V	0.449

So the total clearing I^2t in the application will be $0.449 \times 72000 = \mathbf{32\ 328\ A^2s}$.

Assuming a triangular short-circuit current waveshape, the fault duration can be found from

$$I^2t = \frac{I_{peak}^2 T_{FAULT}}{3}$$

i.e. $32328 = 6705 \times 6705 \times T_{FAULT} / 3$

which gives

$$T_{FAULT} = 2.16 \text{ ms}$$

Assuming a constant I^2t for the thyristor, the thyristor withstand at 2.16 ms is (see p19)

$$I^2t = I_0^2 t_0 \left(\frac{t}{t_0} \right)^{0.333} = 68,000 \left(\frac{2.16}{8.33} \right)^{0.333} = \mathbf{43\ 356\ A^2s}$$

This is greater than the fuse total clearing I^2t so this fuse will protect the thyristor.

Next we check the occasional overload requirement. Referring to the 350A fuse's time-current characteristic, we find that $I_{MELT} = 2482$ A at the 0.1s point. The maximum allowable overload current is $C_{\beta} \times 2482 = 0.75 \times 2482 = \mathbf{1861A}$ for 0.1s. This is acceptable as it is greater than the actual overload current, which is 500% of $144.25A = \mathbf{721A}$ for 0.1s.

Finally, the product datasheet gives the peak arc voltage for this fuse as 1.179kV at the full line voltage of 460V. This is well within the 1.5kV p.i.v. capability of the device.

Hence, the A70QS 350A fuse is suitable for this application.

For the fuse selected in this example the voltage factors K_{AC} and K_{DC} (see section 14) are

$$K_{AC} = \frac{700}{460} = 1.52 \quad \text{and} \quad K_{DC} = \frac{635}{500} = 1.27$$

When considering the commutation fault (non-diametric fault) some designers may wish to increase the fuse a.c. voltage rating to $1.7 \times 460 = 782\text{V}$, as discussed in section 14. In this case the A70QS would not meet the requirement and a higher a.c. voltage rated fuse would have to be used. *(One solution is to check the PSC square bodied fuse rated 1250V/1300V in sizes 70 or 71.* The assessment of the severity of the commutation fault and the need to increase the fuse a.c. voltage rating is one that should be considered carefully even though higher voltage rated fuses add cost to the system. The relatively small added cost in comparison to the possible damage to the system can easily be justified.

18. Select-A-Fuse for Power Electronics (SAF/PE)

Selection of the proper semiconductor fuse for the protection of power electronics circuits can be a time-consuming process. The fuse must have adequate a.c. and d.c. voltage ratings, carry the r.m.s. continuous current, withstand cyclic and surge overloads and clear short-circuit faults, while limiting the I^2t and peak voltage values. The examples in the previous section showed that in practical applications the conditions are not the same as those which were used to determine the published fuse performance data. A lengthy set of calculations is required to adjust the standard data to apply to real world conditions. Often the initial choice of fuse turns out to be unsuitable, and then the calculations have to be repeated for an alternative product.

Select-A-Fuse for Power Electronics software makes it simple. Just enter the application data, click on Search, and the program will give you a list of suitable fuses and their catalog numbers. Fuses are selected using the rules and procedures described in this guide.

The program also contains extensive reference data for Ferraz Shawmut products, such as ratings, I^2t values, time-current and peak let-through curves, and outline drawings.

The data and results of your selections can be saved to a text file for subsequent printing. All graphics screens can be printed directly or copied to the Windows clipboard for pasting into your word-processor.

Data is supplied with SAF/PE for the following semiconductor fuse product families :

- North American (AMPTRAP) round-body fuses with rated a.c. voltages up to 1500V
- IEC standard (PROTISTOR) square and rectangular ceramic body fuses, up to 1250V a.c.

The program is intended for routine applications and contains only part of [Mersen's large range of semiconductor fuse products](#). If you can't find what you need in SAF/PE, contact [Mersen Technical Services](#).

SAF/PE contains thirteen different power conversion circuits as follows :

General converters

- Three-phase bridge
- Three-phase half-wave
- Three-phase double-wye with interphase transformer
- Single-phase bridge
- Single-phase full-wave, center-tap
- Single-phase half-wave
- Six-phase parallel bridge (12-pulse) with balancing reactor

High-power converters (multiple devices in parallel per arm)

- Three-phase bridge
- Three-phase double-wye with interphase transformer
- Six-phase parallel bridge (12-pulse) with balancing reactor

A.C. static switches /soft starters

- Single-phase static switch
- Three-phase static switch / soft starter

Inverters

- Generic three-phase inverter

19. Problem solved using SAF/PE

Fig.30 shows a typical datasheet for a 3-phase GTO inverter. It is desired to protect the inverter with a single fuse in the F_2 location. The fuse is to be selected from the square-bodied PSC range size 3x.

The screenshot displays the 'Inverters Datasheet' software interface. The window title is 'Inverters Datasheet' and it has a menu bar with 'File', 'Options', and 'Help'. The main area is divided into several sections:

- Job title:** Inverter Fuse Selection
- Ambient temperature:** 40.0 degC
- Cooling air speed:** 0.0 m/s
- Circuit elements:**
 - Charging voltage: 800.0 V
 - Filter inductance: 200.00 microH
 - Filter resistance: mOhm
 - Capacitance: 10000.0 microF
 - Leg inductance: 2.0 microH
 - Leg resistance: 0.50 mOhm
- Current loading:** 410.0 Amperes, at location. The dropdown menu is set to 'In supply line (F2)'.
 - Continuous (Set Details)
 - Cyclic load (Set Details)
 - Switching frequency: [] Hz
- Overload:**
 - Single surge (Set Details)
- Number of fuses:** F1: 1, F2: 1
- Use 2 fuses in parallel
- Generic three phase inverter diagram:** Shows a circuit with DC input (V_{dcc}), filter components (L_F, R_F, C), a fuse (F₂), and three inverter legs with diodes (F₁), inductors (L₂), and resistors (R₂).
- Semiconductor circuit parameters:**
 - 10.0 ms I_{2t} limit: 1100.00 kA²s
 - Peak inv voltage: 1.300 kV
 - Adjust I_{2t} for fault time
- Buttons:** Search, Analyse, Close

Fig.30 Input to datasheet in SAF/PE

Clicking on **Search** gives the window shown in Fig.31.

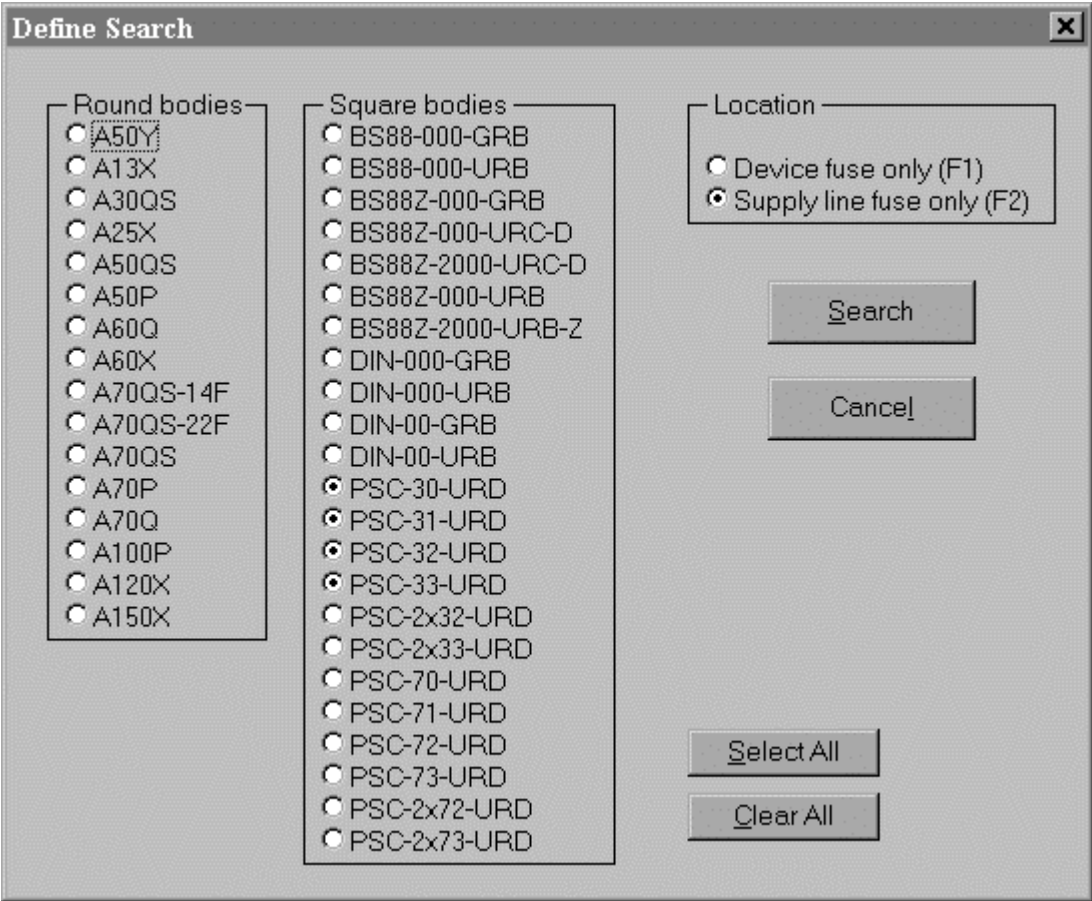

Fig.31 After clicking Search on the datasheet

The square-bodied PSC fuses in sizes 30, 31, 32, and 33 have been selected, and the location set as F₂. Clicking **Search** then gives the screen shown in Fig.32.

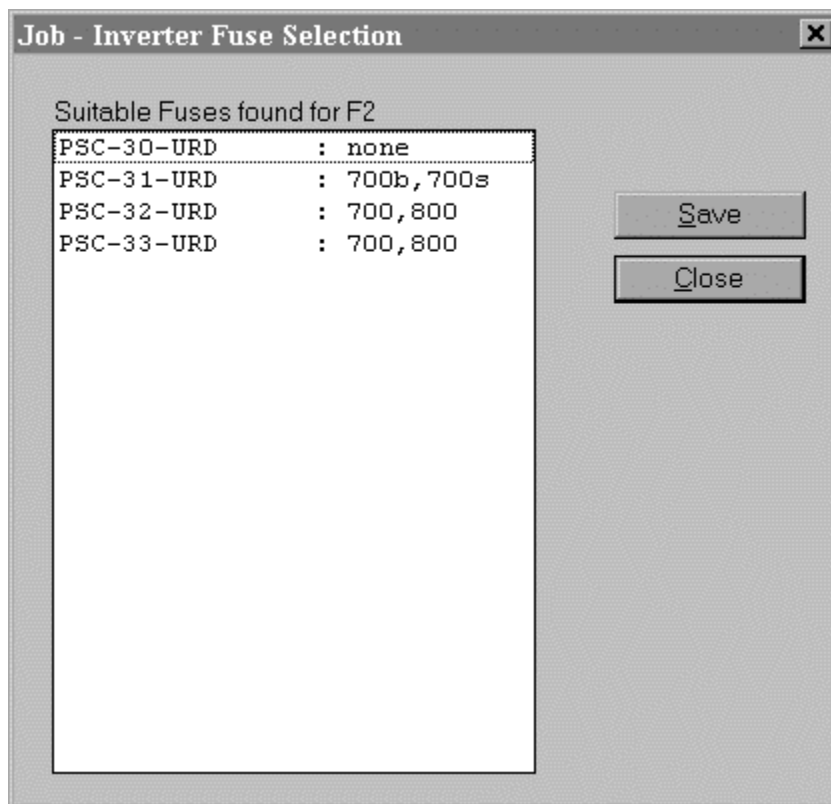

Fig.32 Results of search

The search results show no suitable fuse can be found in size 30 (the smallest physical size). However a 700A fuse in the next larger size 31 would be suitable, and this would normally be the recommended fuse, for reasons of size and cost. (The suffixes *b* and *s* indicate that this fuse is available with both *blade* and *stud* type end contacts).

Double clicking on the PSC-31-URD line (or using the **Analyse** button on the main datasheet) then gives a detailed report. This shows to what extent the 700A fuse meets the requirements of the application, as shown in Fig.33.

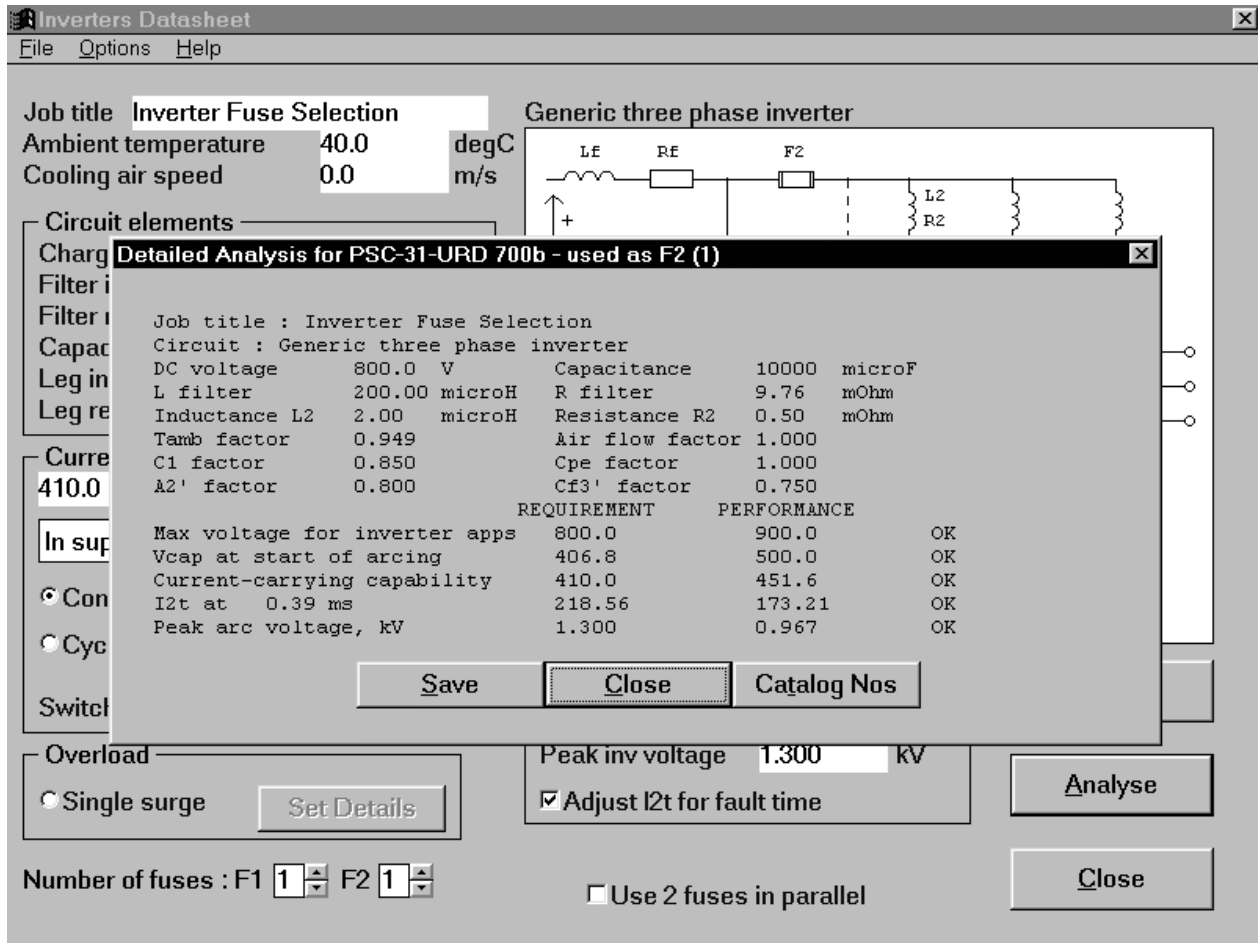

Fig. 33 Detailed analysis for the selected fuse

This section gave a brief illustration of the one of the circuits included in SAF/PE. For further information about SAF/PE contact Mersen Technical Services.

20. Appendix

(a) summary of coefficients used in fuse selection

To allow for :	Coefficient	Notes
ambient temperature	A_1	$A_1 = \sqrt{\frac{a - \theta_a}{a - \theta_0}}$ where θ_a = ambient. $a = 130-150$ °C. $\theta_0 = 25-30$ °C. (See section 5).
forced cooling	B_v	Increases linearly from 1.0 to B_1 at $v = 5$ m/s then constant. Typically $B_1 = 1.25$. (See section 5).
cable/bus size	C_1	To allow for the fact that in service the cooling effect of the connections (cables, busbars) will normally be less favorable than was used in the type tests used for establishing the current rating. (See section 5 and Appendix b).
proximity & skin effect	C_{PE}	To allow for proximity and skin effects at high frequencies. (See section 5).
fluctuations in load current	A'_2	To allow for variations in r.m.s. current - see section 2. Please consult Mersen for cyclic loads. (See section 5).
repetitive cyclic overloads	B'_2	Ratio of the maximum repetitive overload current to the melting current, to ensure that the fuse will endure a given number of cycles. (See section 6).
occasional overload	C_{β}	Ratio of the maximum occasional overload current, in relation to the melting current, to ensure that the fuse will survive without adverse effects. (See section 7).

(b) typical values of C_I for Mersen fuses

FUSE TECHNOLOGY (construction)	SIZE	TYPE	C_I without liquid cooling on terminals	C_I with liquid cooling to keep the fuse contacts below 60 °C on both sides
square	30-31-32-33 & doubles	UR- gR-	0.85 0.85	1.30 1.25
	70-71-72-73 & doubles	UR- gR-	0.90 0.90	1.25 1.20
	83-84 & doubles	UR- gR-	0.90 0.90	1.20 1.15
	91-92-93-94 & doubles	UR- gR-	0.90 0.90	1.10 1.05
	120-121-122-123-124 & doubles	UR- gR-	0.95 1	1 1
	longer bodies	all	1	1
round fibre-glass	130 V to 300 V		0.80	1.30
	500 V to 1000		0.85	1.20
	1100 to 1500 V		0.90	1.10
	1600 V to 3000 V		0.95	1
	above 3000 V		1	1
American ferrules	A13X(amp)-1 or 2 A13Z(amp)-1 or 2 A25X (amp)-1 or 2 A25Z(amp)-1 or 2		0.80	1.30
	A50P(amp)-1,1DS A70P(amp)-1,1DS A60X(amp)-1 A60Z(amp)-1 A100P(amp)-1,1A A100X(amp)-1,1A A100Z(amp)-1,1A		0.85	1.20
	A70QS(rating)-14F 14FI , 22F , 22FI		0.90	1
	A60Q(rating)-2 A120X(rating)-2		0.90	1
	A150P(rating)-1 A150X(rating)-1 or 1W A150Z(rating)-1 or 1W		0.90	1.1
European ferrules	all sizes		according to the rated power of the fuse-holder : see the de-rating table of the holder published in the ADVISOR	

(c) other principal symbols used in this guide

general

r.m.s.	root-mean-square	
I_n	nominal continuous current rating	A
I_n'	continuous current rating in a real-world application	A
I	instantaneous current	A
I^2t	integral of i over a specified period of time	A ² s
θ	temperature	°C
θ_0	reference ambient temperature	°C
θ_a	ambient temperature in a real-world application	°C
v_F	instantaneous voltage across fuse	V
K	I^2t correction factor (for applied voltage)	
V_{PK}	peak arc voltage of fuse	V
K_M	Meyer's constant	A ² s mm ⁻⁴
A	cross-sectional area	mm ²

a.c. circuit

V	r.m.s. source voltage	V
I	r.m.s. prospective (available) short-circuit current	A
f	frequency	Hz
ω	angular frequency (= $2\pi f$)	rad/s
L	inductance	H
R	resistance	Ω
θ	angular instant at which short-circuit occurs w.r.t. voltage wave	rad
ϕ	circuit power-factor angle (= $\tan^{-1} \omega L/R$)	rad
X	circuit inductive reactance (= ωL)	Ω

d.c. circuit

V_{DC}	source voltage	V
T	circuit time constant (= L/R)	s
I_{RMS}	effective r.m.s. current for a specified time	A

cyclic loading

I_{MELT}	r.m.s. current which will cause melting in a specified time	A
I_{RMS}	r.m.s. current over a complete cycle	A
$pu\ RMS$	per-unit r.m.s. loading (= I_{RMS}/I_n)	
K_N, x, y	parameters in cyclic endurance equation	
N	number of cycles	
$\Delta\theta$	highest peak-to-peak temperature excursion within fuse	°C

semiconductor device

I_{FSM}	peak half-cycle surge withstand current of semiconductor device	A
I_0	r.m.s. surge withstand current ($= I_{FSM} / \sqrt{2}$)	A
t_0	duration of half-cycle	s
N	exponent in device withstand formula $I^N t = constant$	

line-commutated converters

F_1	denotes fuse in series with device to be protected	
F_2	denotes fuse in line input to converter (F_1 or F_2 fuses are used, but not both)	
F_3	denotes fuse on d.c. side	
E_{d0}	maximum d.c. output of line-commutated converter	V
v_A, v_B, v_C	instantaneous a.c. source voltages	V
n	number of parallel paths (legs) in high-power converter	
I_{LEG}	r.m.s. current per leg	A
I_F	r.m.s. fault current	A
P	prearcing (melting) I^2t	A ² s
T	total clearing I^2t	A ² s
K_{AC}	a.c. voltage rating factor for regenerative converter	
K_{DC}	d.c. voltage rating factor for regenerative converter	

forced-commutated inverters

R_2, L_2	leg resistance & inductance	Ω, H
R_F, L_F	supply filter resistance & inductance	Ω, H
C	reservoir capacitance	F
E_M	maximum permissible capacitor voltage	V
U_{PM}	maximum permissible capacitor voltage at start of arcing	V

21. Mersen Technical Services Contact Information

REGIONAL OFFICE	TECHNICAL SERVICES CONTACTS
USA	
<p>Mersen 374 Merrimac Street Newburyport, MA 01950-1998 T: 978-465-4853 F: 978-465-6419</p> <p>ep-us.mersen.com</p>	<p>Cindy Cline, Principal Field Engineer Phone: 978-465-4246 Toll-Free Fax: 800-535-8103 cindy.cline@mersen.com technicalservices.nby@mersen.com</p>
CANADA	
<p>Mersen 88 Horner avenue M8Z 5Y3 Toronto Ontario T: 416-252-9371 F: 416-252-9245</p> <p>ep-ca.mersen.com</p>	<p>Lew Silecky, Technical Sales & Marketing Manager T: 416-253-8536 F: 416-252-6572 Lew.SILECKY@mersen.com</p>
EUROPE	
<p>Mersen 15 rue Jacques de Vaucanson F-69720 Saint-Bonnet-de-Mure France T +33 (0) 4 72 22 66 11 F +33 (0) 4 72 22 67 13</p> <p>ep-fr.mersen.com</p>	<p>Julien Bonhomme, Technical Services Technician T: 04 72 22 67 48 F: 04 72 22 69 93 Julien.BONHOMME@mersen.com</p>
ASIA	
<p>Mersen No.55-A6. Shu Shan Road Songjiang 201611 Shanghai Tel: +8621 67602388</p> <p>ep-cn.mersen.com</p>	



MERSEN
Expertise, our source of energy

A WORLD LEADER
in safety & reliability
for electrical power

A GLOBAL PLAYER

Since its foundation in 1892, MERSEN has built an international reputation by creating subsidiaries on all continents. Today with industrial and commercial plants scattered in more than 30 countries, agencies

and representatives in more than 70 countries and 250 commercial contacts throughout the world, MERSEN offers its customers everywhere reliable, high technology products and services backed by its expert technicians.

Mersen U.S.A.
 374 Merrimac Street
 Newburyport, MA 01950
 U.S.A.
 T : 978 462 6662
 F : 978 462 0181
 ep-us.mersen.com

Mersen FRANCE
 15 Rue Jacques de Vaucanson
 F-69720 Saint Bonnet de Mure
 France
 T : +33 (0)4 72 22 66 11
 F : +33 (0)4 72 22 67 13
 ep-fr.mersen.com

Mersen TORONTO
 88 Horner Avenue
 Toronto, Ontario
 Canada M8Z 5Y3
 T : 416 252 9371
 F : 416 252 6572
 ep-ca.mersen.com

Mersen SHANGHAI
 No.55-A6. Shu Shan Road
 Songjiang 201611
 Shanghai
 Tel: +8621 67602388
 ep-cn.mersen.com