

FUSES

What are fuses? They are protective devices that prevent damage to electronic and electrical equipment. Fuses allow electric current to pass through them until the amount of current goes over the fuse's rating. At that time, the fuse "Blows" and stops the flow of electric current. Fuses are rated in amperes, the unit of measure for electric current.

FAST-ACTING vs. SLOW-BLOW. Fast-Acting fuses react quickly to current overloads. Slow-Blow fuses are less sensitive to start-up surge and protect against long-term overloads.

A FUSE IS A SAFETY DEVICE. Always replace a blown fuse with the same type—replace fast-acting with fast acting, slow-blow with slow-blow. Always replace with the same current (Ampere) rating and the same (or Higher) voltage rating.

FUSE TYPE

A major type of slow blow fuse is dual-element fuse. There are four basic types of fuses: (1) Slow Blow/Time lag fuses (2) Dual element slow blow fuses (3) Fast acting fuses (4) Very fast acting fuses

A major type of slow blow fuse is the dual-element fuse. This fuse consists of a short circuit strip and a soldered joint spring connection. During overload conditions the soldered joint gets hot enough to melt and the spring shears the junction loose. Under short circuit conditions, the short circuit element operates to open the circuit. All dual-element fuses are considered to be slow blow but not all slow blow fuses are dual-element.

Slow-blow fuses are ideal for circuits with a transient surge or power-on inrush. These circuits include: motors, transformers, incandescent lamps and capacitate loads.

This inrush may be many times the circuit's full load amperes. The inrush can be 20 times the normal current level. When using fast-acting single-element type fuses it is necessary to rate the fuse at 150% to 300% of the circuit's full load current. With this rating rule inrush may cause nuisance openings.

Slow-blow fuses allow close rating of the fuse without nuisance opening. Typically, rate the slow-blow fuses from 125% to 150% of the circuit's full load amperes.

Fast-acting fuses have no intentional built in time-delay and are used in circuits without transient inrush currents.

Very fast-acting fuses often have silver links. Because of the fuses' current limiting ability, these fuses are frequently used to protect semiconductor circuits.

FUSE PART NUMBER NOMENCLATURE

Fuse part number should include ampere rating and packaging information. See the fuse ordering nomenclature guide below:

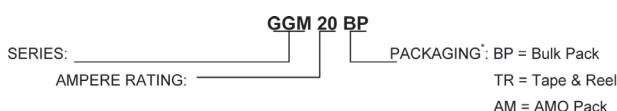

TAPE/REEL IS AVAILABLE FOR ALL AXIAL LEAD FUSES:

FUSE TYPE	A (Pitch)	B (Inside Tape Spacing)
2.8 x 7.1 mm	5mm	53 mm
3.18 x 7.1 mm	5mm	53 mm
3.6 x 10 mm	10mm	56.5 mm
4.5 x 14.5 mm	10 mm	56.5 mm
5 x 20 mm	10 mm	56.5 mm
6 x30 mm	10 mm	56.5 mm
1/4 x 1-1/4 Inch	10 mm	56.5 mm

• To Order, Specify "TR" After Part Number, e.g.

GST-A 1A 250V TR

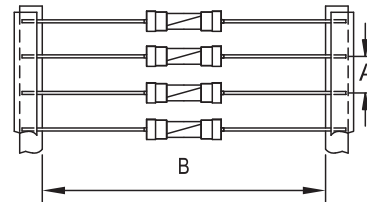

REEL PACKAGING

RADIAL LEAD FORMING TABLE:

FUSE TYPE SIZE	3x10mm (mm)		4.5x14.5mm (mm)		5x20mm (mm)		6x30mm (mm)		1/4x1-1/4Inch (mm)	
	A	B	A	B	A	B	A	B	A	B
AL	13.8	13.8	18	18	25	25	35	35	36	36
AR			18	15	25	20	35	30	36	32
AK			18	16	26	21.5	36	32	37	34
AU	24	6			31.5	5.8				
AUR	23.5	6.5			32.6	6.5				
AUN	20.3	6.3								

• To Order, Specify "AL" or "AR" or "AK" or "AU", e.g.

GST-AL 1A 250V

• Different Values of A & B Available, Please consult Factory

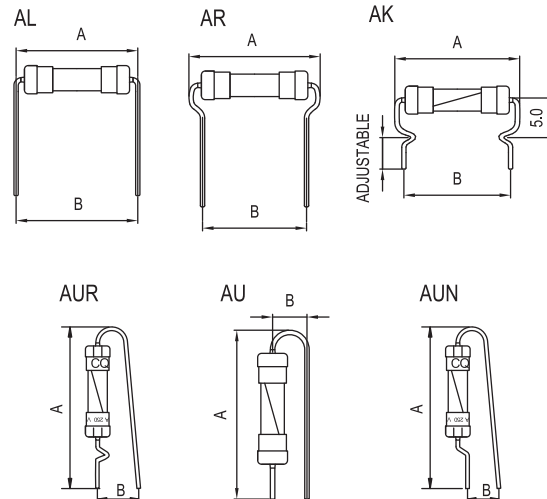

HEAT SHRINK SLEEVE TUBING:

- Pig-Tail Fuses Are Available With Heat-Shrink Tubing Covering The Fuse Body.
- Tubing Prevents Contact With Live Parts, Prevents Shorting To Circuit Traces, And Permits Safe Installation In Tight Spaces.

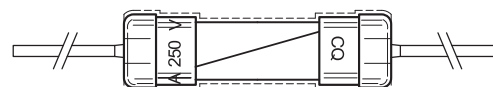

AMPERE RATING

The current carrying capacity of a fuse. The nominal value upon which all performance characteristics of a fuse are based.

AMBIENT TEMPERATURE

The current carrying capacity tests of fuses are performed at 25°C and will be affected by changes in ambient temperature. The higher the ambient temperature, the hotter the fuse will operate, and the shorter its life will be. Conversely, operating at a lower temperature will prolong fuse life. A fuse also runs hotter as the normal operating current approaches or exceeds the rating of the selected fuse. Practical experience indicates fuses at room temperature (25°C) should last indefinitely, if operated at no more than 75% of catalog fuse rating.

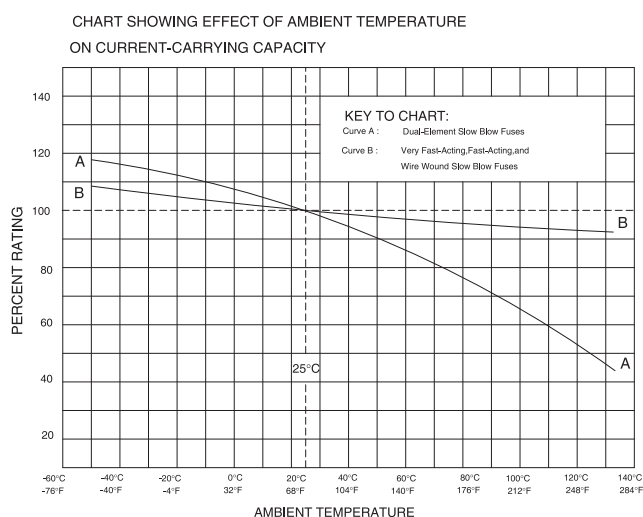

BREAKING CAPACITY (KNOWN AS INTERRUPTING RATING)

The maximum current that a fuse will safely interrupt, at the maximum rated voltage (and any voltage below maximum rated). The rating, which defines a fuse's ability to safely, interrupts and clears short circuits. This rating is much greater than the ampere rating of a fuse. Safe operations require that the fuse remains intact and clear the circuit.

VOLTAGE RATING

For general circuit protection, the voltage rating on the fuse should be equal to, or greater than the circuit voltage of the circuit in which the fuse is applied. Exceeding the voltage rating of a fuse impairs its ability to clear an overload or short circuit safely. Fuse can be used at any voltage below the fuse voltage rating; a 250V fuse can be used in 125V circuits.

OVERCURRENT

A condition which exists on an electrical circuit when the normal load current is exceeded. Overcurrents take on two separate characteristics – overloads and short circuits.

OVERLOAD

Can be classified as an overcurrent which exceeds the normal full load current of a circuit. Also characteristic of this type of overcurrent is that it does not leave the normal current carrying path of the circuit – that is, it flows from the source, through the conductors, through the load, back through the conductors, to the source again.

AMPERE SQUARED SECONDS, I²t

It is the measure of heat energy developed within a circuit during the fuse's clearing. It can be expressed as "melting I²t", "arcing I²t" or the sum of them as "Clearing I²t". "I" stands for effective let-through current(RMS), which is squared, and "t" stands for time of opening, in seconds. The use of I²t values to determine proper fuse typing/rating is only valid under adiabatic conditions, where there is no external heat transfer.

FAST ACTING FUSE

A fuse which opens on overload and short-circuits very quickly. This type of fuse is not designed to withstand temporary overload currents associated with some electrical loads.

TIME-DELAY FUSE

A fuse with a built in delay that allows temporary and harmless inrush currents to pass without opening, but is so designed to open on sustained overloads and short circuits.

CALCULATING PULSE I²t

The energy contained in a current pulse depends on the pulse's waveform's shape, peak current and duration. Determining the energy contained in a particular waveform can be very difficult. Figure 1 presents a variety of waveforms and the corresponding formulas which determine I²t value. Current pulses in most applications can be approximated by one of the waveforms in Figure 1. If a complex waveform is not shown exactly, then it may be possible to break the complex waveform in to a combination of the simpler waveforms shown. The complex waveform's I²t is then estimated as the sum of the I²t values of these other waveforms. The best way to explain how this is done is through an example.



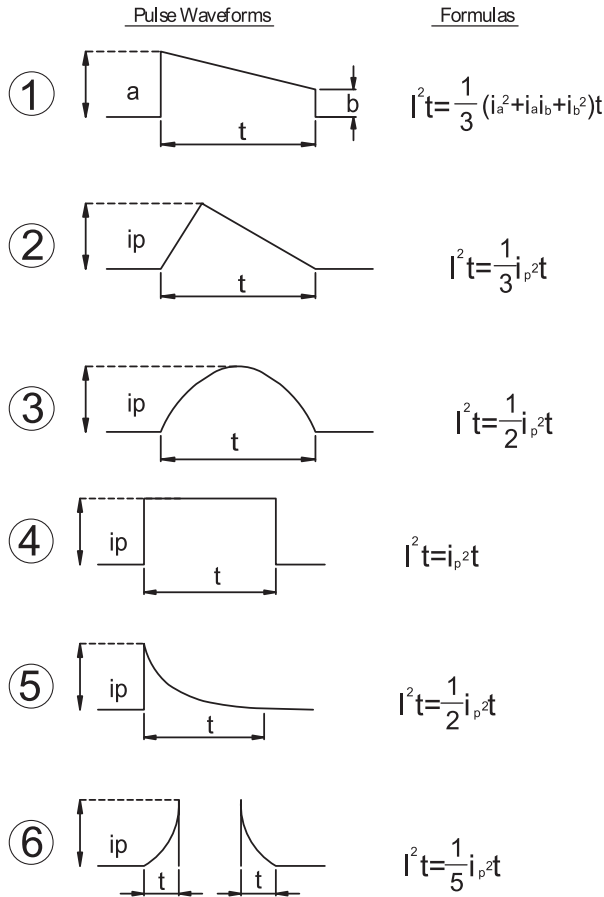

Figure 1 Waveform I²t Formulas

Figure 1

Example:

Select a 250V, Time lag radial lead micro fuse that is capable of withstanding 100,000 pulses of current of pulse waveform shown in Figure 2. The normal operating current is 2 ampere at an ambient temperature of 25°C.

5A/div

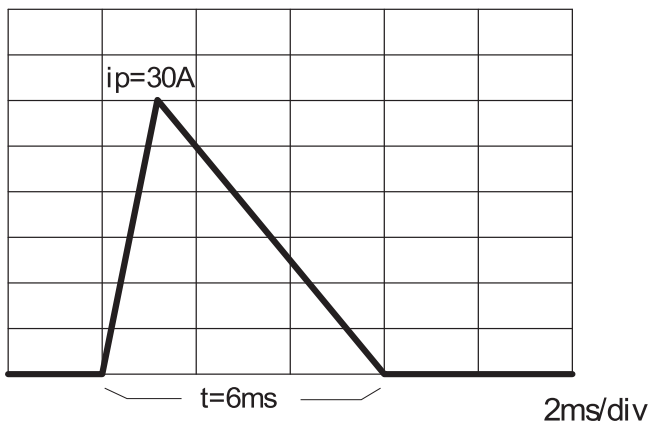

Figure 2

Step 1. Refer to Figure 1 and select the appropriate pulse waveform which is waveform 2 in this example. Place the applicable value for peak pulse current (ip) and time (t) into the corresponding formula for wave shape 2, calculate the result, as shown:

$$\begin{aligned}
 I^2t &= 1/3 (ip)^2t \\
 &= 1/3 \times (30)^2 \times 6 \div 1000 \\
 &= 6A^2Sec
 \end{aligned}$$

This value is referred to as the “Pulse I²t”

Step 2. Determine the required value of Normal Melting I²t by referring to Figure 3. A figure of 22% is shown in Figure 3 for 100,000 occurrences of Pulse I²t calculated in Step 1. This Pulse I²t is converted to its required value of Normal Melting I²t as follows:

$$\begin{aligned}
 \text{Normal Melting } I^2t &= \text{Pulse } I^2t \div 0.22 \\
 &= 6 \div 0.22 \\
 &= 27.27 A^2Sec
 \end{aligned}$$

Pulse Cycle Withstand Capability

100,000 Pulses	Pulse I ² t=22%	Of Nominal Melting I ² t
10,000 Pulses	Pulse I ² t=29%	Of Nominal Melting I ² t
1,000 Pulses	Pulse I ² t=38%	Of Nominal Melting I ² t
100 Pulses	Pulse I ² t=48%	Of Nominal Melting I ² t

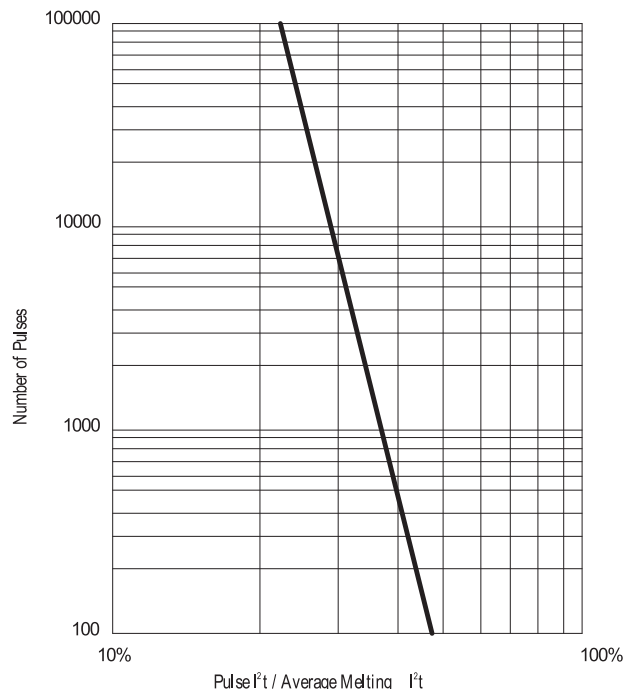

Figure 3

Note: Adequate time (10 seconds) must exist between pulse events to allow heat from the previous event to dissipate.

Step 3. Examine the I²t rating data for the Time lag radial lead micro fuse. The part number MET, 2 ampere design is rated at 32 A²Sec, which is the minimum fuse rating that will accommodate the 27.27 A²Sec calculated in Step 2.