

REV.	DATE	ECO	DESCRIPTION	BY	CK	APP
-	12-15-09	NA	INITIAL RELEASE	JMM	N/A	N/A

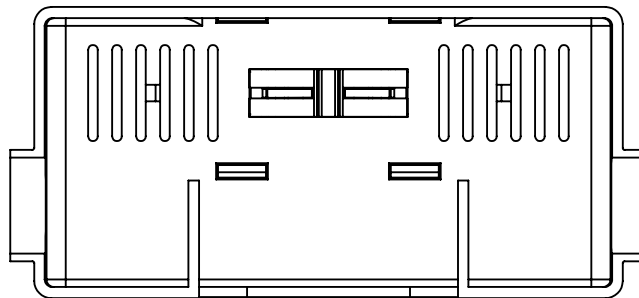

DIMENSIONS IN [] ARE MILLIMETERS

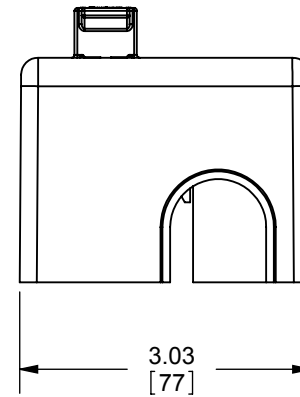
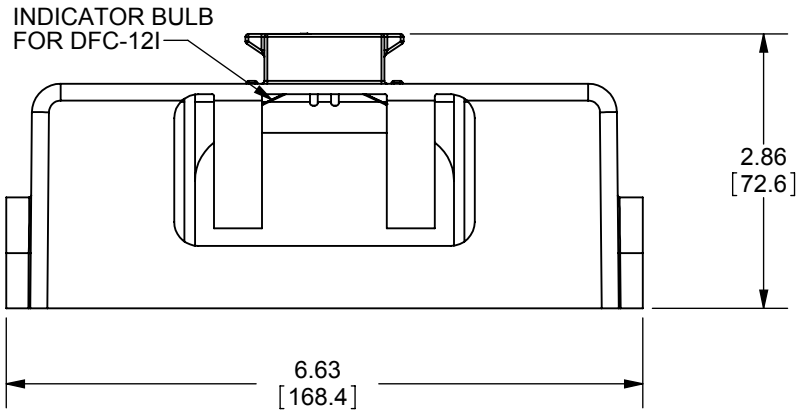
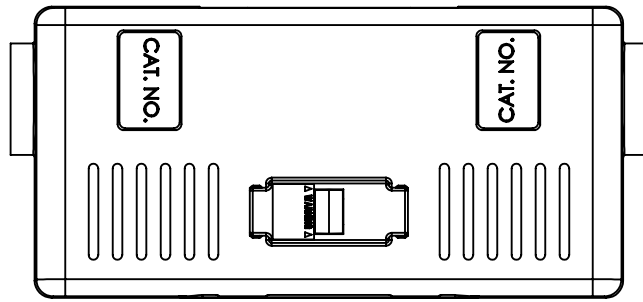

FERRAZ SHAWMUT INC.
374 MERRIMAC STREET
NEWBURYPORT, MA 01950

DFC-12(I)

SAFETY COVER CLASS J

200A 600V

OUTLINE DIMENSIONS
NOT TO BE USED FOR PRODUCTION

701474

PRODUCT MANAGER

DESIGN ENGINEER

SIGN:

SIGN:

DATE:

DATE: