



HELIOPROTECTION®
PROGRAM

SOLUTIONS FOR
PHOTOVOLTAIC

#14



THE COMMITMENT OF MERSEN IN SAFER AND MORE RELIABLE SOLAR PHOTOVOLTAIC INSTALLATIONS

In the solar market, Mersen is a driving force in the development of safer and more reliable solar photovoltaic power installations. Mersen developed the HelioProtection® program, created to protect your solar power installations with components specifically designed for PV applications.

HelioProtection® is a special program of solutions developed by Mersen to enhance innovation and efficiency in the global solar market, and to improve safety and reliability solar installations.

HelioProtection® is a global program offering UL, IEC, CSA and CCC equipment for all components of photovoltaic systems.

1500VDC
READY

800 VAC
READY



HelioProtection® is a brand of Mersen

HelioProtection® Program is the name of the platform of overcurrent and surge protection solutions fully designed for the solar photovoltaic applications.

It is a mix of:

- **Dedication** – the solutions have been specifically designed for protecting PV power systems.
- **Innovation** – the solutions in this program are all on the technological edge and have been tested in our specialized power labs.
- **Expertise** – this program is backed up in the marketplace by a team of experts capable of supporting you from choice to after sales.

SOLAR MARKET OVERVIEW

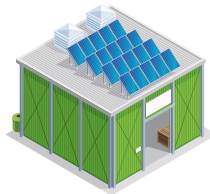

Residential 5 to 36kW

Mersen is a trusted partner of electrical equipment distributors and played a leadership role in solar power circuit protection long before the boom reached the residential market, i.e. for private homes, small apartment buildings and farm buildings.

Commercial and Industrial 36 to 250kW

The walls and roofs of buildings - office towers, factories, malls and warehouses - are among the preferred supports for solar power systems. Architects and developers have grasped the importance of this energy revolution, and more of them are recommending “green” solutions.

Utility and Solar Farm Over 250kW

In this type of application, the architecture is centered on an automatic monitoring and control system. Mersen caters to this critical market with electrical protection that safely and reliably protects the solar power investment.

A

A STRING COMBINER BOX / ARRAY COMBINER BOX

- Fuses & fuse holders -
- Surge protective devices
- Disconnect switches -
- Power distribution blocks
- Monitoring - PV Safety System

B

INVERTER

- Fuses & fuse holders -
- Surge protective devices
- Disconnect switches -
- Power distribution blocks
- Thermal management -
- Contactors - Laminated bus bar

C

AC ELECTRICAL PANELBOARD

- Fuses & fuse holders -
- Surge protective devices -
- Switch disconnectors -
- Fuse switch disconnectors

D

UTILITY DISTRIBUTION NETWORK

- LV Fuses & Fuse holders -
- Fuse switch disconnectors -
- MV Fuses & fuse holders -
- Cables limiters

MERSEN PORTEFOLIO FOR PV APPLICATIONS: A COMPLETE OFFER

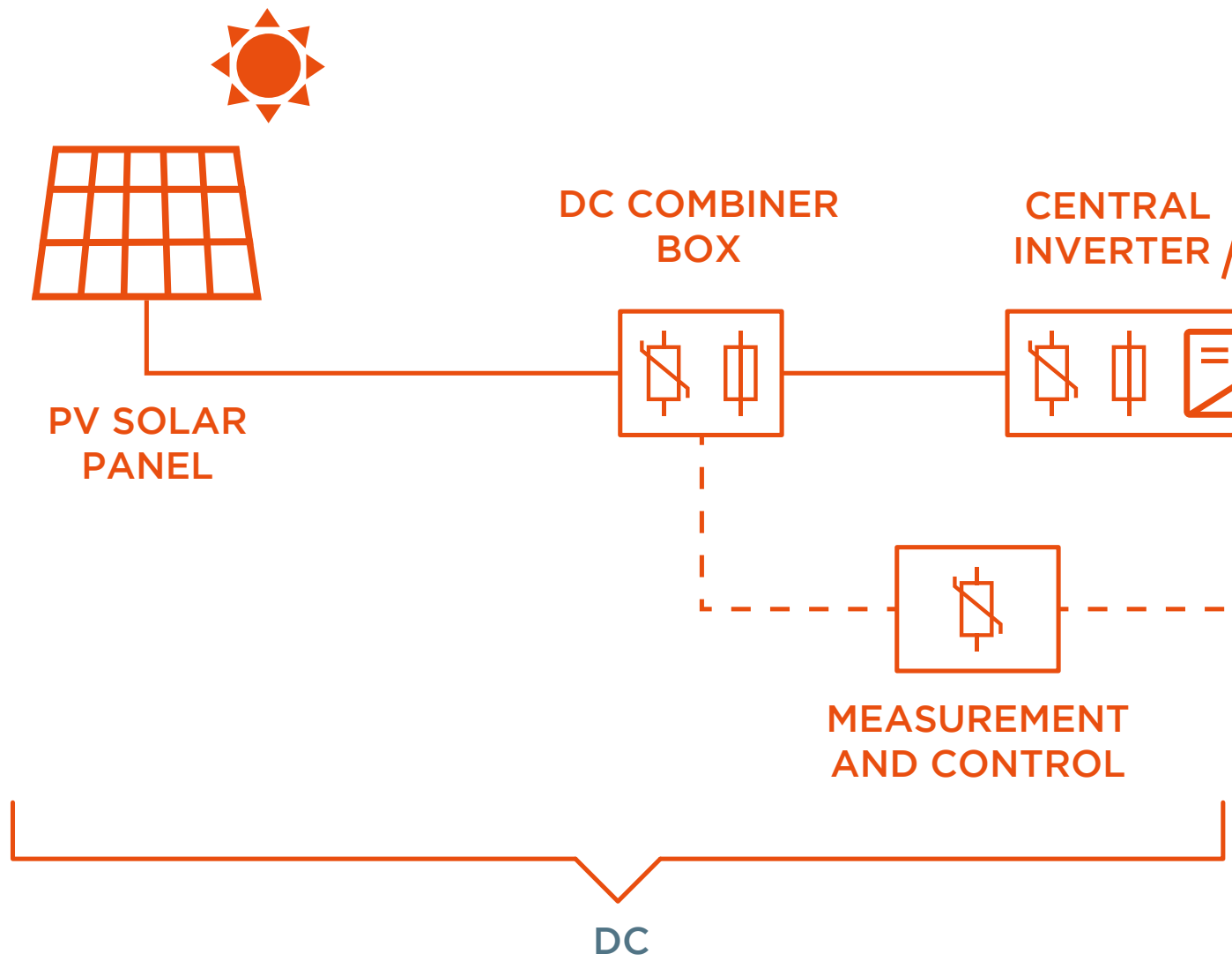

FUSES & FUSES GEARS



SURGE PROTECTION, LIGHTNING PROTECTION AND POWER MONITORING



STRING
INVERTERS

..... AC ELECTRICAL
PANEL BOARD

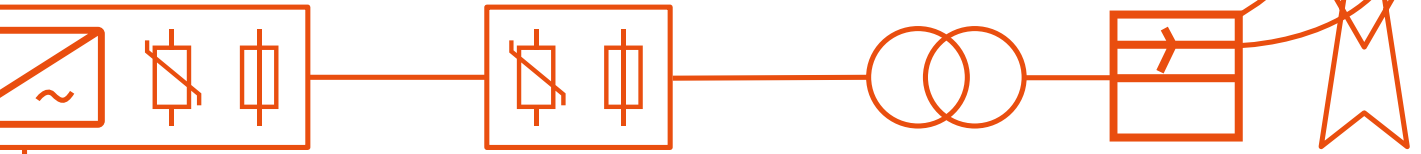

THE GRID

AC

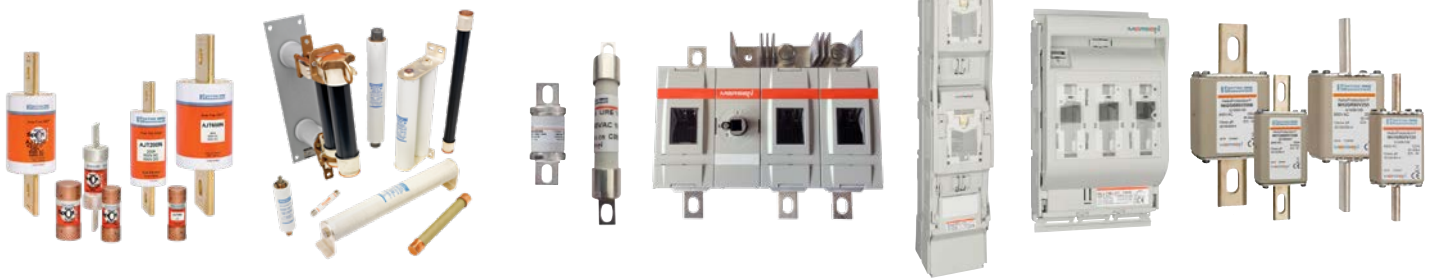

STANDARDIZATION COMPONENTS, SYSTEMS AND INSTALLATIONS

Photovoltaic equipment and systems are governed by international general standards. IEC and UL standards provide the rules to apply to implement state-of-the-art PV installations.

Besides that international or more local standards relay and complete the general standards. They concern more precise fields such as: complete systems and installations, components incorporated in the systems and connection to the grid.



General Standards

IEC 62548 Edition 1

Installation and safety requirements for photovoltaic (PV) generators

Standards, Guidelines, Recommendations

PV Installations PV Systems

IEC 60364-7-712

Low Voltage Installations – PV Installations.

DIN V VDE V0126-5

Junction boxes for photovoltaic modules.

IEC 61439-1

Low voltage switchgear and controlgear assemblies

Surge Protective Devices (SPDs) EN 50539-11

Low voltage surge protective devices – Surge protective devices for specific application including D.C. – Part 11: Requirements and tests for SPDs in photovoltaic applications

Fuses for Photovoltaic Systems

UL 248-19

IEC 60269-6

Low voltage fuses – Part 6: Supplementary requirements for fuse-links for the protection of solar PV energy systems.

Photovoltaic Fuseholders

UL 4248-19

IEC 60269-1

Switches for use in Photovoltaic Systems

UL 98B

IEC 60947-3

PV Power Converters And Grid Connection

IEC 61727

Photovoltaic (PV) systems – Characteristics of the utility interface.

PHOTOVOLTAIC EQUIPMENT PROTECTION BY gPV FUSES

1 - Necessary data required for calculations of photovoltaic protection:

M = number of modules in series in a string (a chain)

N = number of strings (chains) in parallel

For the used module:

IRM = maximum reverse current of a module

Nota: the module is tested according to the standard **61730-2** at a value equal to:

135% x IRM during **2 hours:**
the module has to withstand this condition

Voc STC = open circuit voltage

Isc STC = short circuit current

STC = Standard Test Conditions = irradiance 1 000 W/m², Air Mass 1.5, Cell temperature 25°C

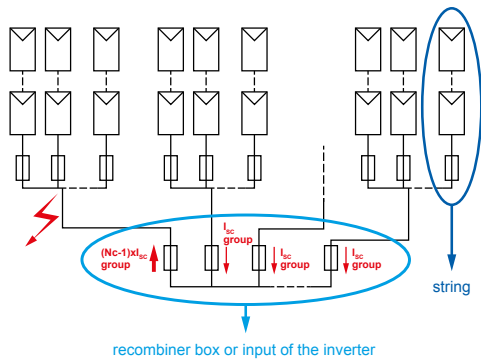

2 - Presence of fuses at the string level:

a) **One or two strings in parallel: fuses are not necessary**

b) **Three or more strings in parallel: the maximum number of strings in parallel without electrical protection is given according to the following formula:**

$$N \leq (1 + IRM / ISC STC)$$

3 - Location of fuses in the strings:

Usually, the usage is to put a fuse on each polarity (positive and negative) of each string in floating circuit configuration, and one otherwise.

4 - Rated voltage required for gPV fuses:

The annex BB of the IEC 60269-6 standard gives information to determine the rated voltage of the gPV fuse-link to be selected.

This voltage has to take into account the **Voc STC of the string** at the lowest application temperature.

Voc STC of the string = $M \times \text{Voc STC of one module}$

At -25 °C the open circuit voltage rises to 1.2 times **Voc STC**

Consequently the **fuse-link rated voltage has to be**

$\geq 1.2 \times \text{Voc STC of the string}$

$\geq 1.2 \times M \times \text{Voc STC of one module}$

Nota: the table 104 of the IEC 60269-6 requires breaking tests carried out at a mean value of recovery voltage fixed at 100 (0->+5) % of the fuse rated voltage. These conditions are the same as those of UL standards **UL 248-19**. So, the coefficient **1.2** is applicable with both IEC and UL fuses.

5 - Rated current required for gPV fuses:

The annex BB of the IEC 60269-6 standard gives information to determine the rated current of the gPV fuse-link to be selected. The same calculation has to be applied to the gPV fuses at the string level and to the gPV fuses at the recombination level or at the input of the inverter.

With **an ambient temperature inside the box lower or equal to 45°C**, the fuse rating has to be higher than or equal to **1.4 x Isc STC** according to IEC 60269-6.

As in practice ambient temperature in the boxes can rise up to 65°C or more, a further derating is needed.

Nota: NEC recommends **1.56 x Isc STC** for ambient temperature lower than **50°C** inside the boxes.

6 - Modules protection against reverse currents:

6a) The corrigendum 1 of the IEC 60269-6 specifies that the tests for the verification of the conventional fusing currents "are deemed to give satisfactory results for operation at **1.35 In** within **two hours**".

The time-current characteristics of Mersen gPV fuses are in concordance with the following gates:

"non melting current = 1.13 x In fuse" and

"melting current = 1.35 x In fuse" and so, Mersen gPV fuses meet the gates requirements of the UL and IEC standards.

6b) On another side, we have seen in paragraph 1 that the modules are tested according to the standard **61730-2** at a value equal to 135% x IRM during two hours

6c) Conclusion for the modules protection:

Conclusion: to protect modules against reverse current, we have to check **1.35 x In fuse** lower or equal to **1.35 x IRM**

Certain withstanding of the module

Certain melting of the fuse

END USER HAS ONLY TO CHECK:

In (fuse rating) has to be lower or equal to IRM (maximum reverse current of the modules)

7 - Fuses gPV at the recombination level:

We apply the rules seen in paragraphs 4 & 5 for the determination of the rated voltage of the gPV fuses and for the determination of their ratings: the end user has to check that the calculated ratings are such that the overload protection of the cables is ensured.

PHOTOVOLTAIC FUSES FOR STRING PROTECTION

HelioProtection® Fuse-links gPV HP6M – 600VDC

Mersen's HP6M photovoltaic (PV) fuse series is designed specifically to protect the PV modules against the reverse currents. These HP6M fuses, designed for low minimum breaking capacity capabilities of 1.35 times the fuse rated current value, allows for safe circuit interruption under typical low fault current conditions produced by PV arrays.



MINIMUM BREAKING CAPACITY = 1.35IN MAXIMUM BREAKING CAPACITY = 10KA				
MAX. OPERATING VOLTAGE = RATED VOLTAGE	RATED CURRENT	CATALOG NUMBER	REFERENCE NUMBER	PACKAGING
600VDC UL Listed CSA Certified IEC 60269-6 Approved [gPV]	1	HP6M1	L1018565	10
	2	HP6M2	M1018566	
	3	HP6M3	N1018567	
	4	HP6M4	Q1018569	
	5	HP6M5	R1018570	
	6	HP6M6	S1018571	
	7	HP6M7	T1018572	
	8	HP6M8	V1018573	
	10	HP6M10	X1018575	
	12	HP6M12	Y1018576	
	15	HP6M15	Z1018577	
	20	HP6M20	A1018578	
	25	HP6M25	K1018610	
30	HP6M30	L1018611		

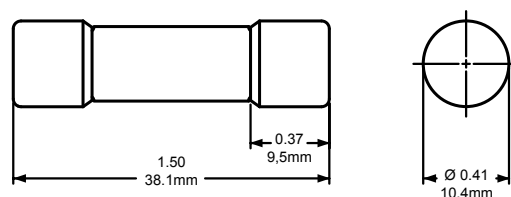

Fuse holders

NB OF POLES	CATALOG NUMBER	REFERENCE NUMBER	NB OF MODULES (17.5MM)	PACKAGING	INDICATOR
1	US101HEL	D1009979	1	12	No
1	US101IHEL	Q1009461	1	12	Yes
1	USGM1HEL	P1022294	1	12	No
1	USGM1IHEL	N1022293	1	12	Yes

Electrical Characteristics

RATED VOLTAGE (V)	NOMINAL CURRENT (A)	CATALOG NUMBER	70% AMP RATING (W)	80% AMP RATING (W)	100% AMP RATING (W)
600	1	HP6M1	0.14	0.19	0.31
600	2	HP6M2	0.19	0.26	0.43
600	3	HP6M3	0.64	0.85	1.4
600	4	HP6M4	0.58	0.77	1.3
600	5	HP6M5	0.65	0.87	1.4
600	6	HP6M6	0.69	0.92	1.5
600	7	HP6M7	-	-	-
600	8	HP6M8	0.92	1.23	2.0
600	10	HP6M10	0.96	1.28	2.1
600	12	HP6M12	1.12	1.49	2.5
600	15	HP6M15	0.99	1.32	2.2
600	20	HP6M20	1.25	1.67	2.8
600	25	HP6M25	1.38	1.84	3.1
600	30	HP6M30	1.5	2.0	3.3

PHOTOVOLTAIC FUSES FOR STRING PROTECTION

HelioProtection® Fuse-links gPV HP10M – 1000VDC

Mersen's HP10M photovoltaic (PV) fuse series is designed specifically to protect the PV modules against the reverse currents. These HP10M fuses, designed for low minimum breaking capacity capabilities of 1.35 times the fuse rated current value, allows for safe circuit interruption under typical low fault current conditions produced by PV arrays.



MINIMUM BREAKING CAPACITY = 1.35IN MAXIMUM BREAKING CAPACITY = 10KA				
MAX. OPERATING VOLTAGE = RATED VOLTAGE	RATED CURRENT	CATALOG NUMBER	REFERENCE NUMBER	PACKAGING
1000VDC UL Listed CSA Certified IEC 60269-6 Approved [gPV]	1	HP10M1	B1018579	10
	2	HP10M2	C1018580	
	3	HP10M3	D1018581	
	4	HP10M4	E1018582	
	5	HP10M5	F1018583	
	6	HP10M6	G1018584	
	7	HP10M7	H1018585	
	8	HP10M8	J1018586	
	10	HP10M10	L1018588	
	12	HP10M12	M1018589	
	15	HP10M15	N1018590	
	20	HP10M20	P1018591	
	25	HP10M25	D1023825	
	30	HP10M30	E1023826	
32	HP10M32	H1062170		

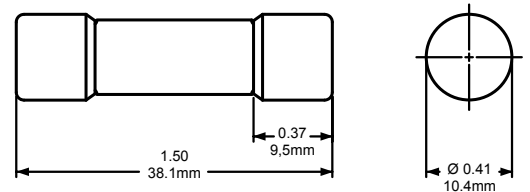

Fuse holders

NB OF POLES	CATALOG NUMBER	REFERENCE NUMBER	NB OF MODULES (17.5MM)	PACKAGING	INDICATOR
1	US101HEL	D1009979	1	12	No
1	US101IHEL	Q1009461	1	12	Yes
1	USGM1HEL	P1022294	1	12	No
1	USGM1IHEL	N1022293	1	12	Yes

Electrical Characteristics

RATED VOLTAGE (V)	NOMINAL CURRENT (A)	CATALOG NUMBER	70% AMP RATING (W)	80% AMP RATING (W)	100% AMP RATING (W)
1000	1	HP10M1	0.125	0.175	0.250
1000	2	HP10M2	0.160	0.250	0.320
1000	3	HP10M3	0.66	0.87	1.36
1000	4	HP10M4	0.69	0.8	1.25
1000	5	HP10M5	0.59	0.73	1.12
1000	6	HP10M6	0.42	0.67	1.05
1000	7	HP10M7	0.40	0.64	1.0
1000	8	HP10M8	0.77	0.88	1.48
1000	10	HP10M10	0.67	0.90	1.5
1000	12	HP10M12	0.72	1.0	1.8
1000	15	HP10M15	0.9	1.3	2.2
1000	20	HP10M20	1.1	1.5	2.8
1000	25	HP10M25	1.3	1.8	3.0
1000	30	HP10M30	1.5	1.9	3.7
1000	32	HP10M32	1.7	2.3	4.2

PHOTOVOLTAIC FUSES FOR STRING PROTECTION

HelioProtection® Fuse-links gPV HP10M – 1000VDC with Crimp Cap

Mersen's HP10M photovoltaic (PV) fuse series with Crimp Cap terminals is designed for in-line fuse applications. The unique wire crimp terminal (CC option) permits solderless wire-to-fuse connection for overmold encapsulation of fuse and wiring.

Mersen photovoltaic fuse series was developed specifically for the protection of PV string wiring for 1000VDC industrial rooftop and utility scale photovoltaic systems. Its robust construction makes it ideal for continuous temperature and current cycling withstand adding to system longevity. Protect your off-grid or grid tied PV system from unexpected ground faults and string faults using Mersen's HelioProtection® fuse line.

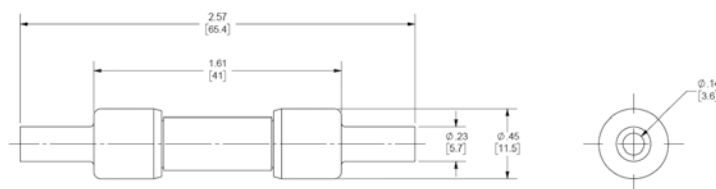

Electrical Characteristics

RATED VOLTAGE (V)	NOMINAL CURRENT (A)	CATALOG NUMBER	REFERENCE NUMBER	70% AMP RATING (W)	80% AMP RATING (W)	100% AMP RATING (W)	INTERRUPTING RATING (KA)	SIZE (MM)
1000	1	HP10M1CC	F1061616	0.14	0.19	0.27	50	10 x 65
	2	HP10M2CC	G1061617	0.17	0.27	0.35		
	3	HP10M3CC	H1061618	0.72	0.95	1.49		
	3.5	HP10M3-1/2CC	J1061619	0.74	0.92	1.43		
	4	HP10M4CC	K1061620	0.76	0.88	1.38		
	5	HP10M5CC	L1061621	0.65	0.80	1.23		
	6	HP10M6CC	J1061527	0.46	0.74	1.15		
	7	HP10M7CC	K1061528	0.44	0.70	1.1		
	8	HP10M8CC	L1061529	0.85	0.97	1.63		
	10	HP10M10CC	M1061530	0.74	0.99	1.65		
	12	HP10M12CC	N1061531	0.79	1.1	1.98		
	15	HP10M15CC	P1061532	0.99	1.43	2.42		
	20	HP10M20CC	Q1061533	1.21	1.65	3.08		
	25	HP10M25CC	R1061534	1.43	1.98	3.3		
30	HP10M30CC	S1061535	1.65	2.09	4.07			
32	HP10M32CC	T1061536	1.70	2.30	4.20			

PHOTOVOLTAIC FUSES FOR STRING PROTECTION

HelioProtection® Modulostar® Modular Fuseholders for gPV fuses-links HP6M and HP10M

The Modulostar HelioProtection® fuse holders from Mersen are very well known in the power low voltage distribution application market. HelioProtection® Fuse gPV were specially designed for PV, and DC more generally speaking, applications.

They comply with both UL 4248-19 and IEC 60269-1 standards and RoHS as well. The plastic parts of our Modulostar HelioProtection® are UL 94 V0 to V2 (Yellow Card). Two models are available: one with and one without blown fuse indication via an indicator light which is on when the fuse is blown (open circuit). The blown fuse indication operates from 220VDC up to 1000VDC.

Characteristics

- **Wiring:** 1-16mm²(16-6AWG)
- **Screw driver heads:** Mersen recommends the use of PZ2 or flat 5.5x1mm screw drivers (max. diameter 6mm)
- **Maximum tightening torque:** 2Nm (17.7lbs.-in)
- DC20B-IP2X.
- **Operating temperature:**
 - 40°C to 70°C with carrier operation
 - 50°C to 90°C without carrier operation

Recommendations

- Do not operate under load.
- **Non insulated conductive parts:** preferably the equipment should be laid out keeping the + and - polarities separate.

MR10 CI

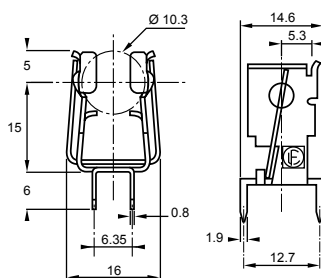

NEW
LINE

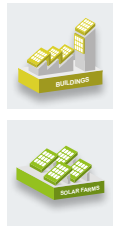

RoHS CE

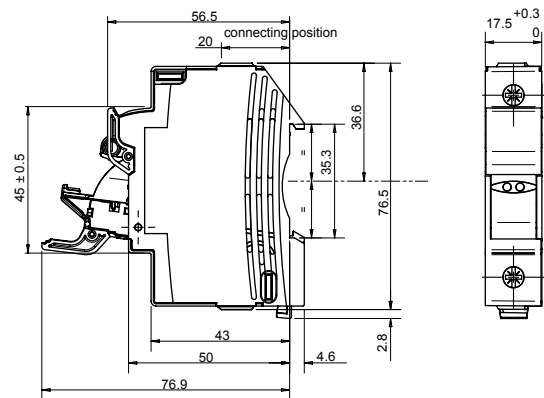

NB OF POLES	CATALOG NUMBER	REFERENCE NUMBER	NB OF MODULES (17.5MM)	PACKAGING	INDICATOR
1	CUS101HEL	K1062724	1	12	Without Ind.
1	CUS101HEL	X1062758	1	12	With Ind.

NOMINAL VOLTAGE U _i DC	VOLTAGE ISOLATION U _{imp}	NOMINAL CURRENT	MAX. POWER LOSSES IN THE FUSE LINKS	FUSE LINKS RATING	CABLE WIRE SECTION (mm ²) RECOMMENDED
1000VDC Pollution Degree 2	6kV	32A	3W	≤12	2.5
	6kV	32A	3W	16	2.5
	6kV	32A	3W	20	2.5
	6kV	32A	3W	25	4
	6kV	32A	3W	30-32	6

Fuse clips

CAT. NUMBER	DESIGNATION	WEIGHT (G)	PACKAGING
MR10RESSORTCI	MR10 CI	4.5	200

PHOTOVOLTAIC FUSES FOR STRING PROTECTION

HelioProtection® USGM1HEL UltraSafe™ Fuseholders

Innovative UltraSafe™ midget fuseholders with screw-less, spring pressure, wire termination technology



Mersen's new USGM series fuseholders deliver the ultimate ease-of-use, time (labor) saving and reliable solution available in the marketplace. Mersen is the first manufacturer to offer screw-less, spring pressure, wire termination technology into a power fuseholder, delivering the best of both technologies to its customers. They comply with UL 4248-19 standard and IEC 60947-3. Now you can experience the combined benefits of safety, ease-of-use, labor savings and reliability of UltraSafe™ fuseholders and spring pressure technology.

Recommended Fuse Usage:

- USGM1HEL use with Photovoltaic Fuses: HP6M, HP10M.

Additional Specifications:

- **Screw-less, spring pressure terminals:** WAGO CAGE CLAMP®.
- **Wire Range:**
#14 to 6 AWG (2.5 to 16mm²) Single Conductor;
#14 to 10 AWG (2.5 to 5.0mm²) Dual Conductor.
- **Wire Type:**
60/75/90°C Solid/Stranded Copper.

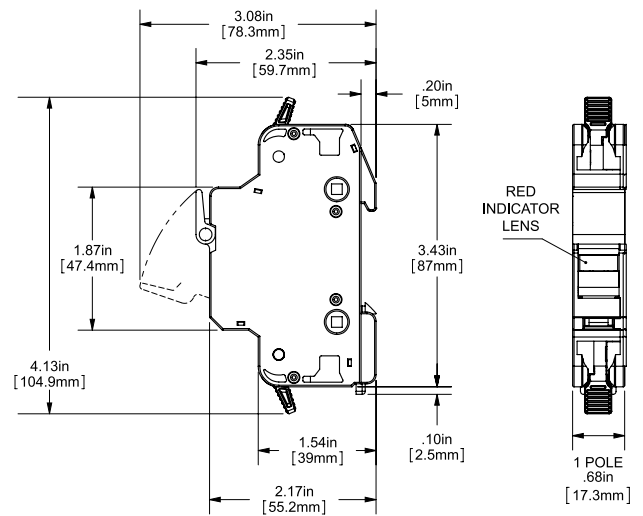

Ratings:

- **Volts:** 1000VDC maximum
- **Amps :** 30A maximum
- **SCCR :** 200kA AC, 100kA DC

FUSE TYPE	NO. OF POLES	VOLTAGE RATING	AMPERE RATING	VISUAL INDICATION	CATALOG NUMBER	REF. NUMBER	PACKAGING
Photovoltaic	1	1000VDC	30	No	USGM1HEL	P1022294	12
				Yes	USGM1HEL	N1022293	12

PHOTOVOLTAIC FUSES FOR STRING PROTECTION

HelioProtection® Fuse-links gPV DC10HEL 10x85 - 1200VDC

Mersen's 10x85 photovoltaic (PV) fuse series is designed specifically to protect the PV modules against the reverse currents. These 10x85 fuses, designed for low minimum breaking capacity capabilities of 1.35 times the fuse rated current value, allows for safe circuit interruption under typical low fault current conditions produced by PV arrays. They are rated 1200V and meet the trend for increasing the maximum open circuit voltage across the PV modules.

DC HelioProtection® Fuse complies with new IEC 60269-1 and with the new 60269-6 introducing the gPV type of fuse.



Basics characteristics

SIZE	MAXIMUM OPERATING VOLTAGE FOR L/R ≤ 0,5ms	RATED CURRENT	OPERATION	BREAKING CAPACITY @ Un	POWER LOSSES END CONTACTS		CATALOG NUMBER	REFERENCE NUMBER	PACKAGING
					0.7In	0.8In			
mm	V	A		kA	W	W			
D10xL85	1 200	8	gPV type	10	1,3	1,7	DC10HEL12C8	D1014188	45
		10			1,3	1,7	DC10HEL12C10	T1012017	45
		12,5			1,3	1,9	DC10HEL12C12,5	X1008754	45
		16			1,5	2,1	DC10HEL12C16	Y1008755	45
		20			1,8	2,5	DC10HEL12C20	Z1008756	45
	900	25	2,2	3	DC10HEL9C25	A1008757	45		

Drawing

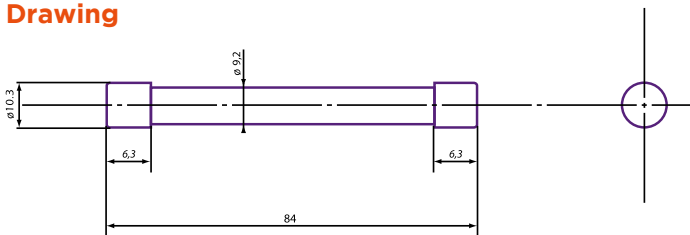

Fuse clips

CATALOG NUMBER	REFERENCE NUMBER	DESIGNATION	WEIGHT (G)	PACKAGING
MR10RESSORTCI	Y098507	MR10 CI	4.5	200
MR10RESSORTCI	Y098507	MR10CI	4.5	1000

MR10 CI

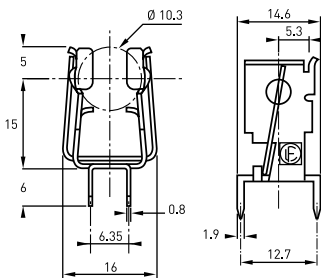

MR10

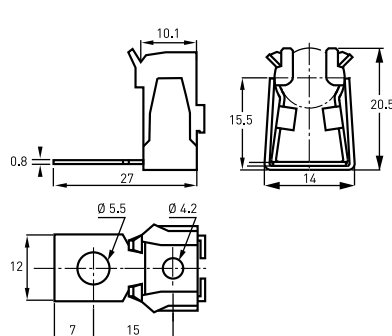

MR10 without compressor

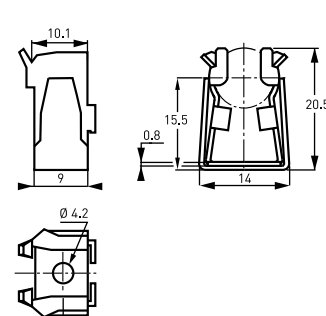

PHOTOVOLTAIC FUSES FOR STRING PROTECTION

HelioProtection® Fuse-links gPV HP15M 1500VDC Midget (10x85mm)

Engineered to protect photovoltaic applications

Mersen's HP15M photovoltaic (PV) fuse series was engineered and designed specifically for the protection of photovoltaic systems. Its enhanced fuse construction makes it ideal for continuous temperature and current cycling withstand adding to system longevity. The 1500VDC rated HP15M, designed for low minimum breaking capacity capabilities of 1.35 times the fuse rated current value, allows for safe circuit interruption under typical low fault current conditions produced by PV arrays. Protect your off-grid or grid tied PV system from unexpected ground faults and line faults using Mersen's Helio Protection fuse line.

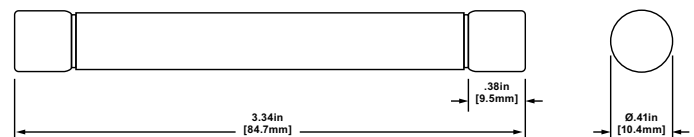

Features/Benefits:

- Low fault current interrupting capability
- Durable construction for enhanced system longevity
- Temperature cycle withstand capability
- Guaranteed operation at temperature extremes
- Globally accepted
- Recommended Fuse holder: US15MIHEL

Applications:

- All photovoltaic applications
- PV string/array level protection
- Combiner box applications
- In-line PV module protection
- Inverters
- Battery charge controllers



CATALOG NUMBER	REFERENCE NUMBER	RATED CURRENT In (Amps)	POWER DISSIPATION AT 0.7xIn (Watts)	POWER DISSIPATION AT 0.8xIn (Watts)	POWER DISSIPATION AT 1.0xIn (Watts)	PACKAGING
HP15M4	F1059569	4	0.79	1.09	1.85	5
HP15M5	X1055053	5	0.84	1.16	1.97	5
HP15M6	Q1053667	6	0.97	1.37	2.42	5
HP15M7	R1053668	7	0.97	1.37	2.43	5
HP15M8	S1053669	8	1.04	1.50	2.60	5
HP15M10	T1053670	10	1.23	1.77	3.09	5
HP15M12	V1053671	12	1.15	1.70	2.89	5
HP15M15	W1053672	15	1.39	1.91	3.48	5
HP15M20	X1053673	20	1.71	2.47	4.28	5
HP15M25	Y1053674	25	2.13	3.08	5.35	5
HP15M30	Z1053675	30	2.56	3.61	6.40	5
HP15M32	G1059570	32	2.73	3.85	6.82	5

Ratings:

- Volts: 1500VDC
- Amps: 5A - 30A
- SCCR: 50kA

Approvals:

- UL Listed to Standard UL 248-19
- CSA Component
- IEC 60269-6

HP15G types also exist from 2.5 to 5A, gPV 1500VDC, in 10mmx57mm size, to be associated with MR10 fuse clips.

PHOTOVOLTAIC FUSES FOR STRING PROTECTION

HelioProtection® Fuse-links gPV HP15M with crimp cap 1500VDC Midget (10x85mm)

Mersen's HP15M photovoltaic (PV) fuse series with Crimp Cap terminals is designed for in-line fuse applications. The unique wire crimp terminal (CC option) permits solderless wire-to-fuse connection for overmold encapsulation of fuse and wiring.

Mersen photovoltaic fuse series HP15M is designed specifically for the protection of PV string wiring for 1500VDC utility scale photovoltaic systems. Its robust construction makes it ideal for continuous temperature and current cycling withstand adding to system longevity. The 1500VDC rated HP15M, designed for low minimum breaking capacity capabilities of 1.35 times the fuse rated current value, allows for safe circuit interruption under typical low fault current conditions produced by PV arrays and meets the trend for increased voltage for higher efficiency.

Protect your off-grid or grid tied PV system from unexpected ground faults and line faults using Mersen's HelioProtection® fuse line.

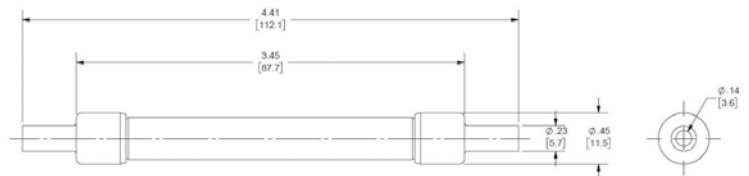

CC terminal: Recommended crimping tool:
T & B Sta-Kon ERG4002 #10 -12 AWG (6-4 mm²)

Features/Benefits:

- Low fault current interrupting capability
- Durable construction for enhanced system longevity
- Temperature cycle withstand capability
- Guaranteed operation at temperature extremes
- Globally accepted
- Recommended Fuse holder: US15M1HEL

Applications:

- All photovoltaic applications
- PV string/array level protection
- Combiner box applications
- In-line PV module protection
- Inverters
- Battery charge controllers



Catalog Numbers / Electrical Specs

CATALOG NUMBER	REFERENCE NUMBER	RATED CURRENT In (Amps)	POWER DISSIPATION AT 0.7xIn (Watts)	POWER DISSIPATION AT 0.8xIn (Watts)	POWER DISSIPATION AT 1.0xIn (Watts)	PACKAGING
HP15M4CC	A1061542	4	0.80	1.04	1.69	5
HP15M5CC	B1061543	5	0.92	1.27	2.16	5
HP15M6CC	D1061545	6	1.06	1.50	2.66	5
HP15M7CC	E1061546	7	1.06	1.50	2.67	5
HP15M8CC	F1061547	8	1.14	1.65	2.86	5
HP15M10CC	G1061548	10	1.35	1.94	3.34	5
HP15M12CC	H1061549	12	1.26	1.87	3.18	5
HP15M15CC	J1061550	15	1.53	2.10	3.83	5
HP15M20CC	K1061551	20	1.88	2.71	4.71	5
HP15M25CC	L1061552	25	2.34	3.39	5.88	5
HP15M30CC	M1061553	30	2.81	3.97	7.04	5
HP15M32CC	N1061554	32	3.00	4.23	7.51	5

Ratings:

- Volts: 1500VDC
- Amps: 5A - 30A
- SCCR: 50kA

Approvals:

- UL Listed to Standard UL 248-19
- CSA Component
- IEC 60269-6

PHOTOVOLTAIC FUSES FOR STRING PROTECTION

HelioProtection® US15M1HEL

UltraSafe™ Fuseholders for gPV fuse-links HP15M

Touch-safe design increases user safety

Mersen UltraSafe™ modular fuse holders introduce the next level of safety for Photovoltaic applications for 10x85mm fuses. UltraSafe™ fuseholders are finger safe up to an IP20 grade of protection, and the 10x85mm features a pull out, pivoting fuse carrier.

The US15M1HEL is designed with terminals to accept standard stock busbar eliminating the need for custom combed busbar, saving cost, time and simplifying installation. The body features industry leading UL 94V0 material, providing superior flammability rating with exceptional durability.

Features/Benefits:

- Bus bar termination clamp
- UL 94V0 Material Flammability Rating
- Wire terminal for use with 90°C wire
- Wire range:
 - 6 – 14 AWG stranded,
 - 10 – 14 AWG solid,
 - Copper wire only
- IP20 Finger Safe
- Din Rail Mounting
- Recommended fuse usage: HP15M

Applications:

- All photovoltaic applications
- Combiner box applications

Ratings:

- **Volts:** 1500VDC Maximum
- **Amps :** 30A Maximum
- **SCCR:** 50kA

Approvals:

- UL Recognized Component, evaluated to UL 4248-19
- Evaluated to IEC60269-1

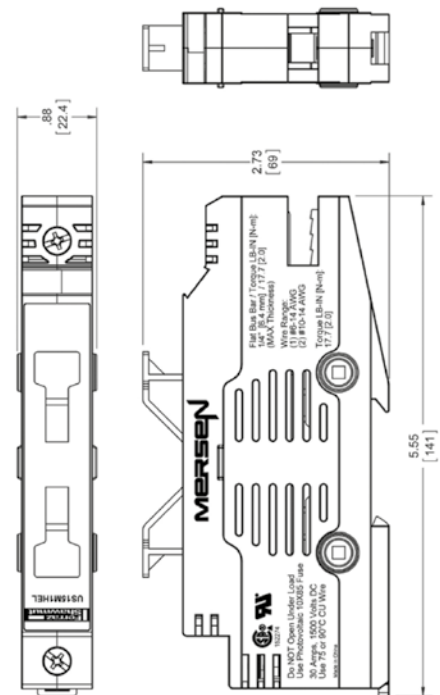

PHOTOVOLTAIC FUSES FOR STRING PROTECTION

Helioprotection® HP15FHM32 Series fuseholders for gPV fuse-links HP15M

NEW LINE

Mersen's 1,500 VDC HeliProtection fuse holders for 10/14x85mm gPV fuses introduce the next level of safety for Utility scale photovoltaic applications. The HP15FHM32 fuse holders are finger safe (IP20 ingress protection rated), featuring a rotating fuse carrier, similar to the Mersen UltraSafe™ fuse holders. The HP15FHM32 series input and output terminals accept standard PV rated wiring and comb bus bars, providing added versatility for end-use installations. The body features high performance UL 94 V-0 rated polymer material, providing superior flammability rating, with exceptional durability and dielectric withstand properties.



Features/Benefits:

- Wire in/out terminals
- Clamping:
 - HP15FHM32A: Screw clamp, #2 combo head
 - HP15FHM32B: tool-less spring clamp (screw-less, spring pressure, wire termination technology)
- UL 94 V-0 rated
- Use with PV-rated copper wire
- Wire range:
 - 1X #4 - #14 AWG (25 - 2.5 mm²);
 - 2X #8 - 18 AWG (10 - 0.75 mm²)
- Required terminal torque
 - HP15FHM32A: 22 in-lb/2.5Nm
 - HP15FHM32B: 1X #6 - #14 AWG (18 - 2.6 mm²); 2X #10-14 AWG (8 - 2.5 mm²)
- IP20 rated (finger safe)
- 35 mm DIN Rail Mounting
- Lock Out/Tag Out feature
- Area for customer-applied labeling
- Digital Multimeter (DMM) probe access
- Accepts 10/14 x 85mm gPV fuses
- Recommended gPV fuses: HP15M
- Operating Temperature: -40 to +125°C

Ratings:

- **Volts:** 1500VDC Maximum
- **Amps:** 32ADC Maximum
- **Power Dissipation:** 6.0 W Maximum
- **SCCR:** 50kA ADC

Applications:

- All Utility scale photovoltaic applications
- 1500VDC Combiner Boxes
- PV Ground Fault protection

Approvals:

- UL 4248-19
- CSA 22.2 No. 4248.19
- IEC 60269-2

Dimensions (mm):

HP15FHM32A (Screw Clamp)

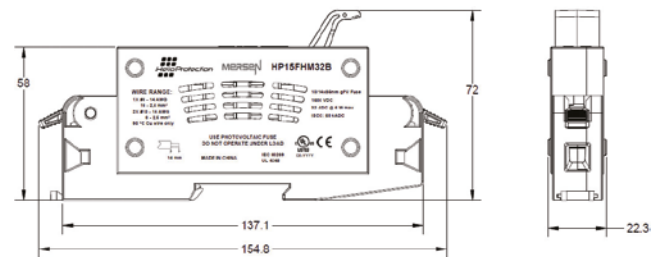
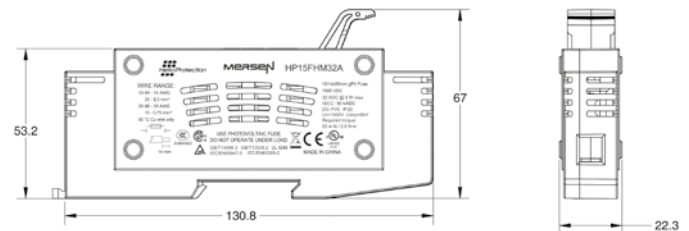

FUSE TYPE	NO. OF POLES	VOLTAGE RATING	AMPERE RATING	CATALOG NUMBER	PACKAGING
Photovoltaic	1	1500VDC	32	HP15FHM32A	12
Photovoltaic	1	1500VDC	32	HP15FHM32B	12

PHOTOVOLTAIC FUSES FOR ARRAY PROTECTION

HelioProtection® Fuse-links HP10NH 1000VDC



Mersen HP10NH photovoltaic (PV) fuse series was engineered and designed specifically for the protection of photovoltaic systems. HelioProtection® HP10NH fuse links are designed for the protection of cables in a PV group of chains when a short circuit occurs in a panel (main fuse category). This HelioProtection® main fuse range enlarges our PV fuse links offering on a size having a worldwide acceptance. They are of the gPV type and comply with both IEC 60269-6 and UL 248-19 PV standards.

Features/Benefits:

- Global acceptance
- Low fault current interrupting capability
- Temperature cycle withstand capability
- Durable construction for enhanced system longevity
- High efficiency with low power losses
- Small footprint

Applications:

- All photovoltaic applications
- Inverter DC input protection
- Re-combiner applications (sub combiner, array combiner, master combiner)



Ratings:

- 1000VDC
- IR = 50kA (L/R = 1ms)

Approvals:

- IEC 60269-6
- UL 248-19
- RoHS compliance



SIZE	RATED VOLTAGE (V)	NOMINAL CURRENT (A)	CLASS	PLAIN BLADE			DIRECT MOUNTING		POWER DISSIPATION AT In	POWER DISSIPATION AT 0,7xIn	PACKAGE
				CATALOG NUMBER	REFERENCE NUMBER	WEIGHT (KG)	CATALOG NUMBER	REFERENCE NUMBER			
NH1	1000VDC	50	gPV	HP10NH1GPV50	Z1028283	0.4	HP10NH1GPV50B	B1048663	11	4.6	3
		63		HP10NH1GPV63	A1028284	0.4	HP10NH1GPV63B	C1048664	13	5.4	3
		80		HP10NH1GPV80	B1028285	0.4	HP10NH1GPV80B	D1048665	15	6.1	3
		100		HP10NH1GPV100	C1028286	0.4	HP10NH1GPV100B	E1048666	17	7.2	3
		125		HP10NH1GPV125	D1028287	0.4	HP10NH1GPV125B	F1048667	18	7.4	3
		160		HP10NH1GPV160	E1028288	0.4	HP10NH1GPV160B	G1048668	23	9.6	3
NH2		200		HP10NH2GPV200	X1037619	0.63	HP10NH2GPV200B	H1048669	29	12	3
		250		HP10NH2GPV250	Y1037620	0.63	HP10NH2GPV250B	J1048670	34	14	3

Plain blade dimensions (mm)

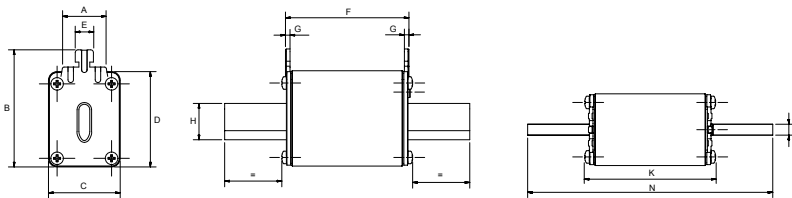

Direct mounting dimensions (mm)

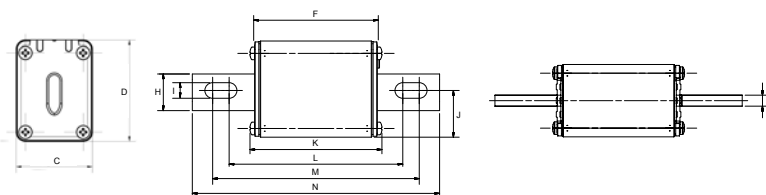

		A	B	C	D	E	F	G	H	I	J	K	L	M	N	O
PLAIN BLADE	NH1	24	64.5	39.5	52.5	10	68	2.5	20	-	-	72.1	-	-	135	6
	NH2	24	72	51	60	10	68	2.5	26	-	-	72	-	-	150	6
DIRECT MOUNTING	NH1	-	-	39.5	-	-	68	-	20	8.5	25.5	-	99.8	117.8	150	6
	NH2	-	-	51	60	-	68	-	26	10.5	27	72	99.8	117.8	150	6

PHOTOVOLTAIC FUSES FOR ARRAY PROTECTION

Photovoltaic Fuse bases 1000VDC



HPBB11PPR

NH fuse-bases for NH fuse-links gPV 1000VDC, size 1, 250A, single pole



CATALOG NUMBER	REFERENCE NUMBER	POWER ACCEPTANCE	RATED IMPULSE WITHSTAND VOLTAGE Uimp	DESIGN	PACKAGE
HPBB11PPR	A1030607	32 W	8 kV	open design, for DIN-rail or screw mounting, for NH fuse links size 1	3
HPBB11PPRFS	K1032916	32 W	8 kV	with touch protection, for DIN-rail or screw mounting, for NH fuse links size 1	3



HPBB21PPR

NH fuse-bases for NH fuse-links gPV 1000VDC, size 2, 315A, single pole



CATALOG NUMBER	REFERENCE NUMBER	POWER ACCEPTANCE	RATED IMPULSE WITHSTAND VOLTAGE Uimp	DESIGN	PACKAGE
HPBB21PPR	C1037509	45 W	8 kV	open design, for DIN-rail or screw mounting, for NH fuse links size 1 and 2	3
HPBB21PPRFS	D1037510	45 W	8 kV	with touch protection, for DIN-rail or screw mounting, for NH fuse links size 1 and 2	3

NH fuse-base for short NH fuse-links gPV, sizes 1, type PP, open design (dimensions in mm)

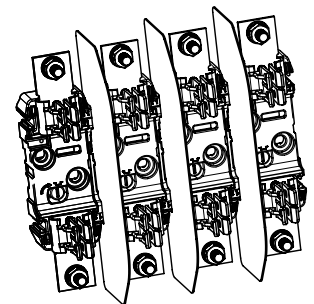
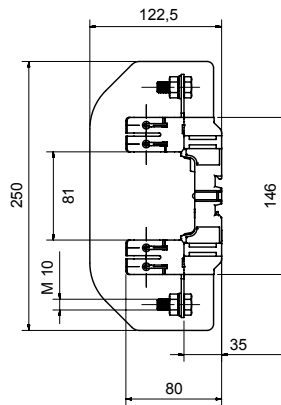
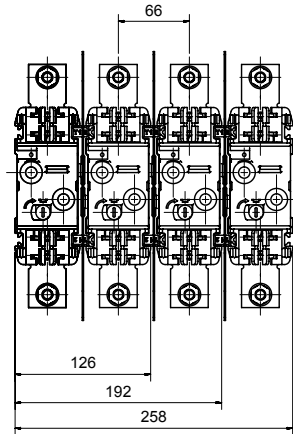
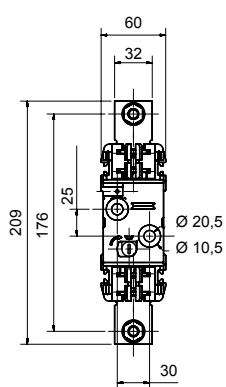

In case of multipole units in parallel without barriers a distance of 8mm must be considered between the live parts of the fuses.

NH fuse-base for short NH fuse-links gPV, sizes 2, type PP, open design (dimensions in mm)

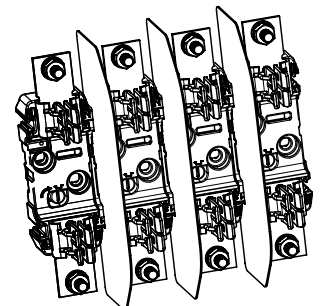
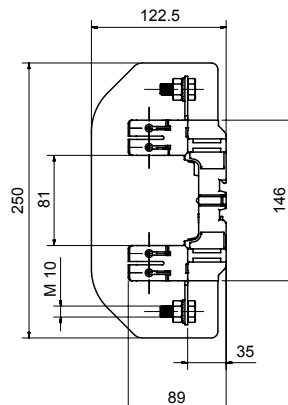
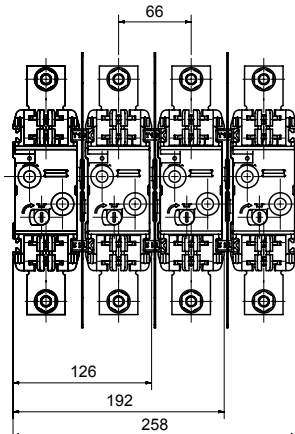
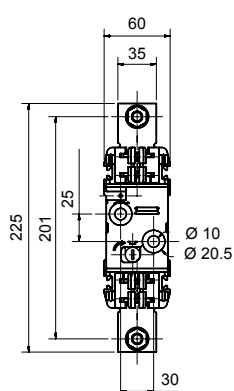

In case of multipole units in parallel without barriers a distance of 8mm must be considered between the live parts of the fuses

PHOTOVOLTAIC FUSES FOR ARRAY PROTECTION

HelioProtection® Fuse-links gPV HP12NH – 1250VDC



Mersen HP12NH photovoltaic (PV) fuse series was engineered and designed specifically for the protection of photovoltaic systems.

HelioProtection® HP12NH fuse-links are designed for the protection of cables in a PV group of chains when a short circuit occurs in a panel (main fuse category). This HelioProtection® main fuse range enlarges our PV fuse-links offering on a size having a worldwide acceptance. They are of the gPV type and comply with both IEC 60269-6 and UL 248-19 PV standards.

Features/Benefits:

- Global acceptance
- Low fault current interrupting capability
- Temperature cycle withstand capability
- Durable construction for enhanced system longevity
- High efficiency with low power losses

Applications:

- All photovoltaic applications
- Inverter DC input protection
- Re-combiner applications (sub combiner, array combiner, master combiner)



Ratings:

- 1250VDC
- IR = 50kA (L/R = 1ms)

Approvals:

- CEI 60269-6
- UL 248-19
Conformité
RoHS



SIZE	RATED VOLTAGE (V)	NOMINAL CURRENT (A)	CLASS	PLAIN BLADE			DIRECT MOUNTING		POWER DISSIPATION AT 0,7xIn	POWER DISSIPATION AT In	PACKAGE
				CATALOG NUMBER	REFERENCE NUMBER	WEIGHT (KG)	CATALOG NUMBER	REFERENCE NUMBER			
NH1XL	1250VDC	125	gPV	HP12NH1XLGPV125	G1039744	0.435	HP12NH1LGPV125B	K1048671	12	29	1
		160		HP12NH1XLGPV160	H1039745	0.698	HP12NH1LGPV160B	L1048672	14	34	1
200		HP12NH2XLGPV200		J1039746	1.054	HP12NH2LGPV200B	M1048673	16	42	1	
NH2XL		250		HP12NH2XLGPV250	K1039747	1.054	HP12NH2LGPV250B	N1048674	17	45	1
NH3L		250		HP12NH3LGPV250	Z1033389	1.66	HP12NH3LGPV250B	P1048675	18	46	1
		315		HP12NH3LGPV315	A1033390	1.66	HP12NH3LGPV315B	Q1048676	22	53	1
		350		HP12NH3LGPV350	B1033391	1.66	HP12NH3LGPV350B	R1048677	23	55	1
		400		HP12NH3LGPV400	C1033392	1.66	HP12NH3LGPV400B	S1048678	29	73	1

Plain blade dimensions (mm)

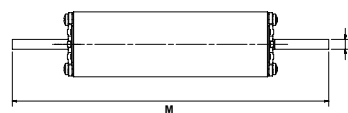
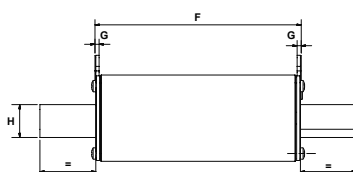
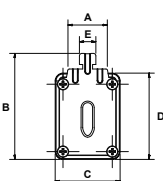

Direct mounting dimensions (mm)

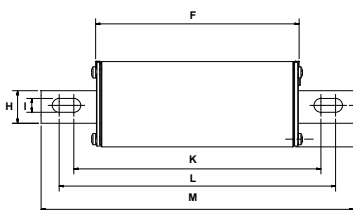
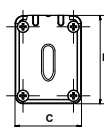

		A	B	C	D	E	F	G	H	I	J	K	L	M	N
PLAIN BLADE	NH1XL	24	64.5	39.5	52.5	10	125.5	2.5	20	-	-	-	-	192.5	6
	NH2XL	24	72	51	60	10	123	2.5	26	-	-	-	-	205	6
	NH3L	25	84.5	70	74	10	123	2.5	33	-	-	-	-	205	6
DIRECT MOUNTING	NH1XL	-	-	39.5	52.5	-	125.5	-	20	8.5	25.5	152.3	170.3	192.5	6
	NH2XL	-	-	51	60	-	123	-	26	10.5	27	154.8	172.8	205	6
	NH3L	-	-	70	74	-	123	-	33	10.5	33	163.2	176.2	205	6

PHOTOVOLTAIC FUSES FOR ARRAY PROTECTION

HelioProtection® Fuse-link gPV HP15NH – 1500VDC

Mersen HP15NH photovoltaic (PV) fuse serie was engineered and designed specifically for the protection of photovoltaic systems. Helio-Protection® HP15NH fuse links are designed for the protection of cables in a PV group of chains when a short circuit occurs in a panel (main fuse category). This HelioProtection® main fuse range enlarges our PV fuse links offering on 1XL/2XL/3L sizes having a worldwide acceptance. They are of the gPV type and comply with both IEC 60269-6 and UL 248-19 PV standards.

They are available with bolted type blades for direct mounting and with striker.

Features/Benefits:

- Global acceptance
- Low fault current interrupting capability
- Temperature cycle withstand capability
- Durable construction for enhanced system longevity
- High efficiency with low power losses
- Available in 3 versions: plain blade, direct mounted, direct mounted with striker

Applications:

- All photovoltaic applications
- Inverter DC input protection
- Re-combiner applications (sub combiner, array combiner, master combiner)



Approvals:

- IEC 60269-6
- UL 248-19 (E358319, Volume 1, Section 1)
- RoHS compliance

NH-fuse-links gPV 1500VDC Plain Blade

CATALOG NUMBER	ITEM NUMBER	SIZE	RATED CURRENT I _N	POWER DISSIPATION AT I _N	POWER DISSIPATION AT 0.7X I _N	PACKAGE
HP15NH1XLGPV50	A1061266	1XL	50 A	21 W	8.6 W	1
HP15NH1XLGPV63	Z1064508	1XL	63 A	25 W	10.2 W	1
HP15NH1XLGPV80	A1064509	1XL	80 A	25.5 W	10.3 W	1
HP15NH1XLGPV100	B1064510	1XL	100 A	26 W	10.5 W	1
HP15NH1XLGPV125	C1064511	1XL	125 A	30 W	12.2 W	1
HP15NH2XLGPV125	H1064309	2XL	125 A	33.7 W	13.6 W	1
HP15NH2XLGPV160	J1064310	2XL	160 A	38 W	15.4 W	1
HP15NH2XLGPV200	K1064311	2XL	200 A	48 W	19.4 W	1
HP15NH2XLGPV250	L1064312	2XL	250 A	51.7 W	20.9 W	1
HP15NH3LGPV160	H1037859	3L	160 A	36 W	15 W	1
HP15NH3LGPV200	J1037860	3L	200 A	44 W	18 W	1
HP15NH3LGPV250	K1037861	3L	250 A	50 W	20 W	1
HP15NH3LGPV315	L1037862	3L	315 A	57 W	23 W	1
HP15NH3LGPV350	M1037863	3L	350 A	63 W	25 W	1
HP15NH3LGPV400	N1037864	3L	400 A	71 W	28 W	1

PHOTOVOLTAIC FUSES FOR ARRAY PROTECTION

NH-fuse-links gPV 1500VDC Direct Mounting

CATALOG NUMBER	ITEM NUMBER	SIZE	RATED CURRENT I_N	POWER DISSIPATION AT I_N	POWER DISSIPATION AT $0.7I_N$	PACKAGE
HP15NH1LGPV50B	D1065431	1XL	50 A	21 W	8.6 W	1
HP15NH1LGPV63B	D1065432	1XL	63 A	25 W	10.2 W	1
HP15NH1LGPV80B	E1065433	1XL	80 A	25.5 W	10.3 W	1
HP15NH1LGPV100B	F1065434	1XL	100 A	26 W	10.5 W	1
HP15NH1LGPV125B	G1065435	1XL	125 A	30 W	12.2 W	1
HP15NH2LGPV125B	M1064313	2XL	125 A	33.7 W	13.6 W	1
HP15NH2LGPV160B	N1064314	2XL	160 A	38 W	15.4 W	1
HP15NH2LGPV200B	P1064315	2XL	200 A	48 W	19.4 W	1
HP15NH2LGPV250B	Q1064316	2XL	250 A	51.7 W	20.9 W	1
HP15NH3LGPV160B	T1048679	3L	160 A	36 W	15 W	1
HP15NH3LGPV200B	V1048680	3L	200 A	44 W	18 W	1
HP15NH3LGPV250B	W1048681	3L	250 A	50 W	20 W	1
HP15NH3LGPV315B	X1048682	3L	315 A	57 W	23 W	1
HP15NH3LGPV350B	Y1048683	3L	350 A	63 W	25 W	1
HP15NH3LGPV400B	Z1048684	3L	400 A	71 W	28 W	1

NH-fuse-links gPV 1500VDC Direct Mounting size 3L with striker

CATALOG NUMBER	ITEM NUMBER	RATED CURRENT I_N	POWER DISSIPATION AT I_N	POWER DISSIPATION AT $0.7I_N$	POWER DISSIPATION AT $0.8 I_N$	PACKAGE	WEIGHT
HP15NH3LPV160BI	A1057218	160 A	36 W	15 W	20 W	1	1.66 kg
HP15NH3LPV200BI	B1057219	200 A	44 W	18 W	25 W	1	1.66 kg
HP15NH3LPV250BI	C1057220	250 A	50 W	20 W	28 W	1	1.66 kg
HP15NH3LPV315BI	D1057221	315 A	57 W	23 W	32 W	1	1.66 kg
HP15NH3LPV350BI	E1057222	350 A	63 W	25 W	35 W	1	1.66 kg
HP15NH3LPV400BI	F1057223	400 A	71 W	28 W	40 W	1	1.66 kg



Microswitch for NH-fuse-link gPV 1500VDC size 3L (with striker)

CATALOG NUMBER	ITEM NUMBER	RATED CURRENT I_N	RATED IMPULSE WITHSTAND VOLTAGE U_{IMP}	INDICATION SYSTEM	PACKAGE	WEIGHT
MC3E1-5N	D310020	5 A	20 kV	standard	3	32 g

Special purpose gPV fuse-link size 1XL Direct Mounting without striker and without lugs

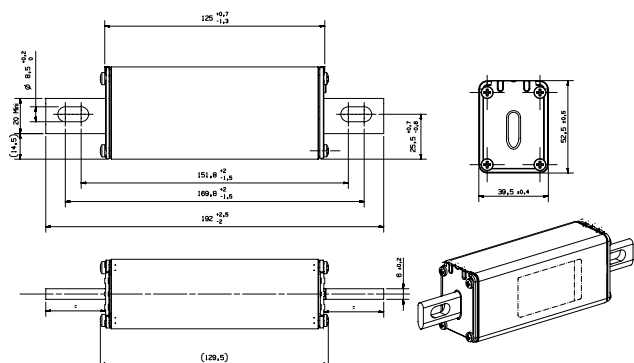

Special purpose gPV fuse-link size 2XL Direct Mounting without striker and without lugs

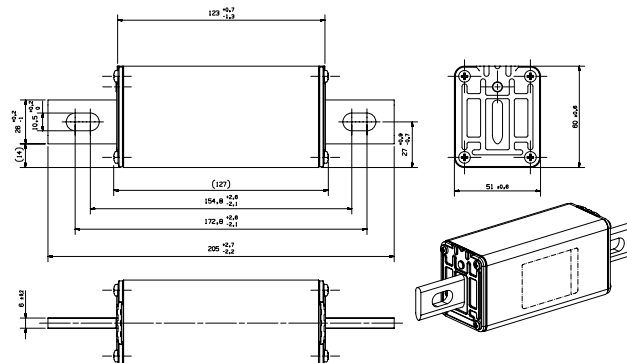

PHOTOVOLTAIC FUSES FOR ARRAY PROTECTION

Special purpose gPV fuse link Plain Blade size 1XL

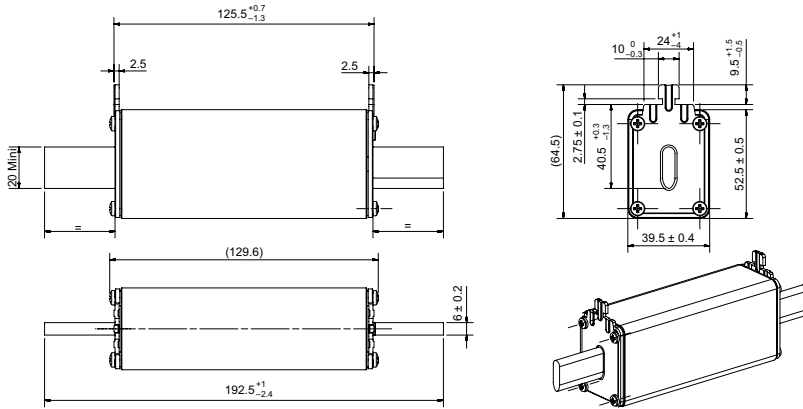

Dimensions in mm

Special purpose gPV fuse link Plain Blade size 2XL

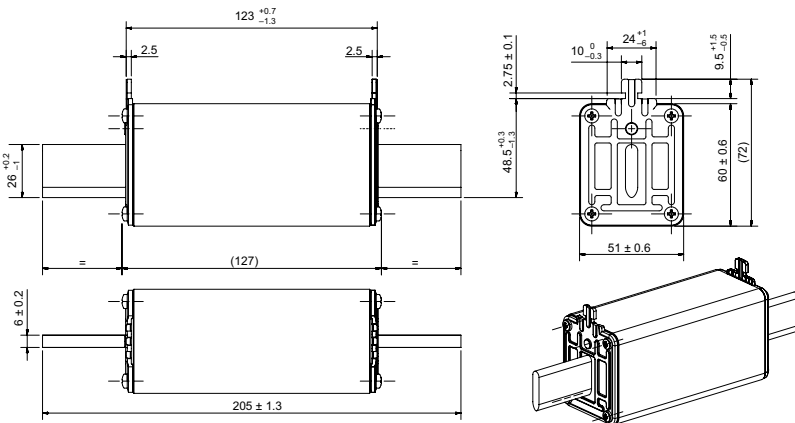

Dimensions in mm

Special purpose gPV fuse-link size 3L Plain Blade without striker

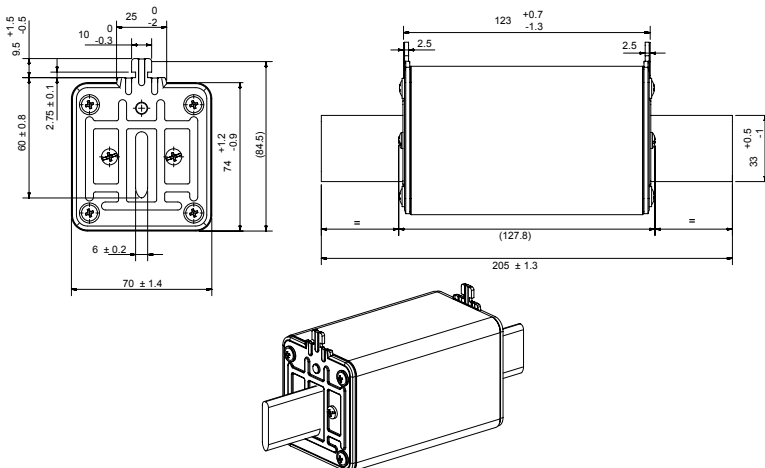

Dimensions in mm

PHOTOVOLTAIC FUSES FOR ARRAY PROTECTION

Special purpose gPV fuse-link size 3L Direct Mounting without striker and without lugs

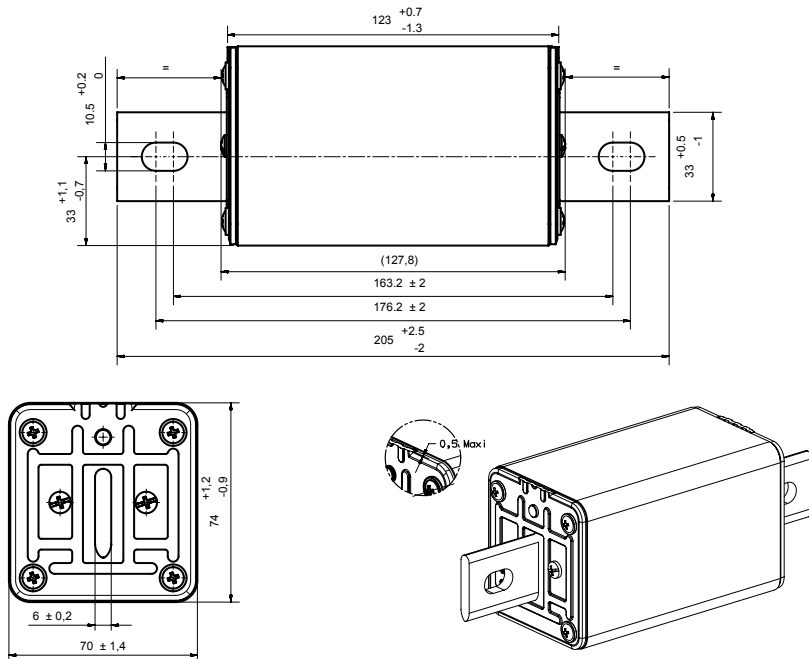

Dimensions in mm

Special purpose gPV fuse-link size 3L Direct Mounting with striker and without lugs

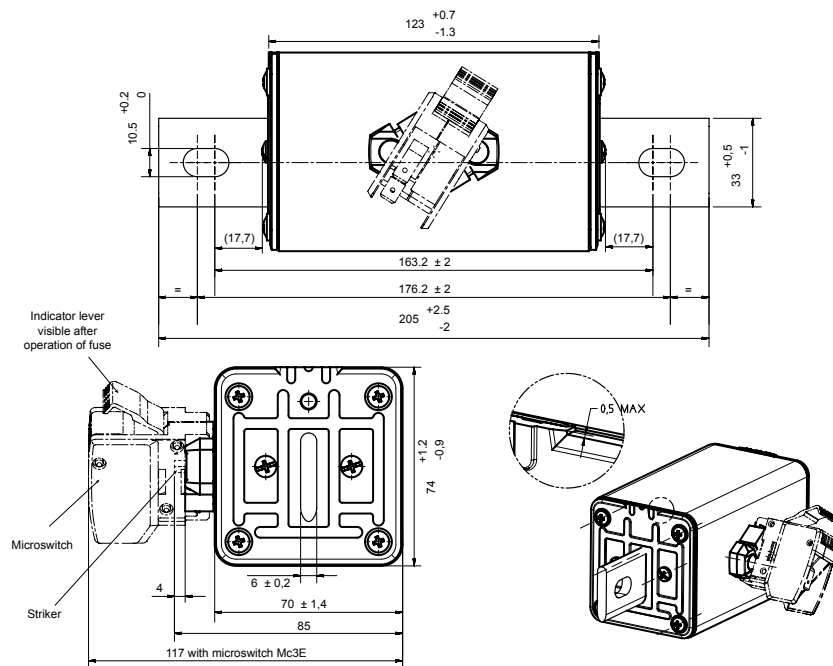

Dimensions in mm

PHOTOVOLTAIC FUSES FOR ARRAY PROTECTION

Photovoltaic Fuse bases 1500VDC - Protected version

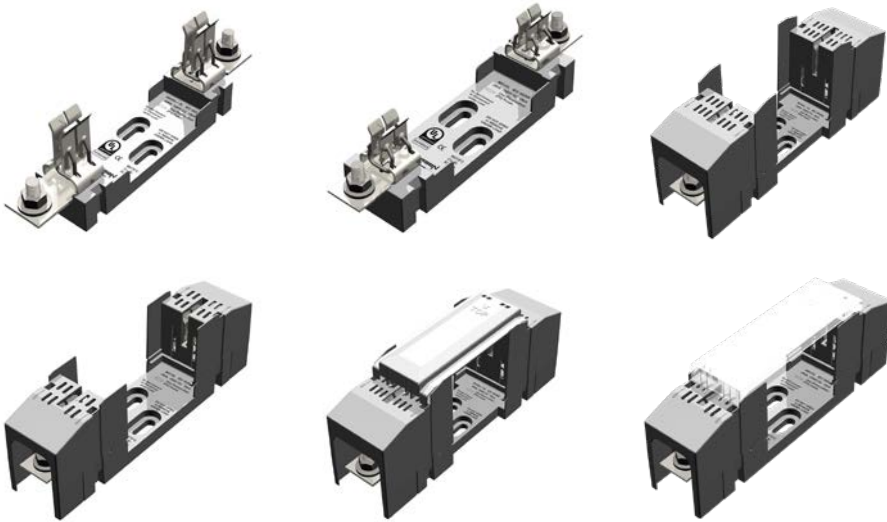

Fuse-bases for NH gPV fuse-links, single pole, 1500VDC, 50 kA, SCCR 15kA



CATALOG NUMBER	ITEM NUMBER	SIZE	RATED CURRENT I _N	POWER ACCEPTANCE	RATED IMPULSE WITHSTAND VOLTAGE U _{IIMP}	CABLE TERMINATION	DESIGN	PACKAGE
HP15FHH1XLA	J1064586	1XL	250 A	50 W	6 kV	M10 terminal screws M = 32Nm for cable lugs 25-240 mm ²	open design, screw mounting, for NH1XL fuse-links with blade contacts	4
HP15FHH1XLB	K1064587	1XL	250 A	50 W	6 kV	M10 terminal screws M = 32Nm for cable lugs 25-240 mm ²	with touch-safe protection, screw mounting, for NH1XL fuse-links with blade contacts	4
HP15FHH3LA	L1064588	2XL-3L	600 A	100 W	6 kV	M12 terminal screws M = 32Nm for cable lugs 25-300 mm ²	open design, screw mounting, for NH2XL and NH3L fuse-links with blade contacts	4
HP15FHH3LB	M1064589	2XL-3L	600 A	100 W	6 kV	M12 terminal screws M = 32Nm for cable lugs 25-300 mm ²	with touch-safe protection, screw mounting, for NH2XL and NH3L fuse-links with blade contacts	2

Cover for fuse-base with touch protection

CATALOG NUMBER	ITEM NUMBER	DESIGN	PACKAGE
COVERFHH1XL	N1064590	pack of 4 gripping lug covers for NH1XL fuse-base with touch protection	1
COVERFHH3L	P1064591	pack of 2 gripping lug covers for NH3L fuse-base with touch protection	1

PHOTOVOLTAIC FUSES FOR ARRAY PROTECTION

NH fuse base for gPV fuse-link 1XL open design and with touch-safe protection

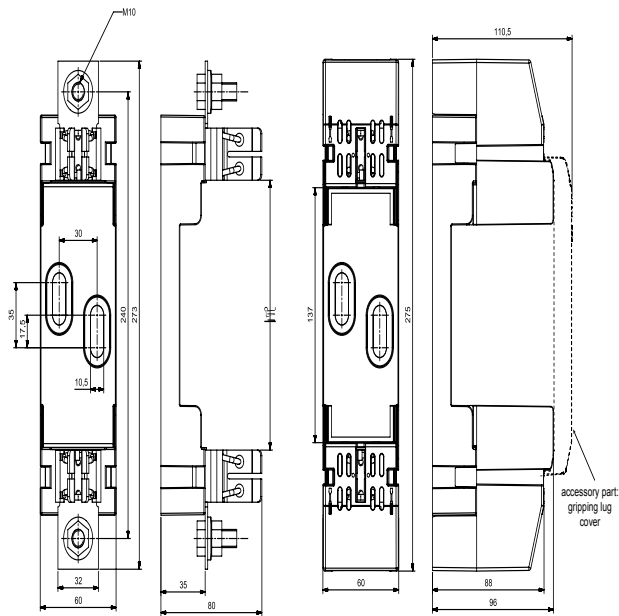

Dimensions in mm

NH fuse base for gPV fuse-link 2XL and 3L, open design

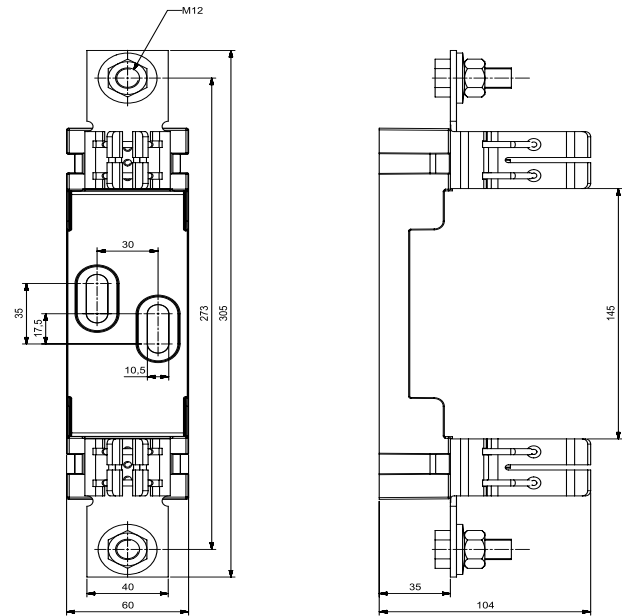

Dimensions in mm

NH fuse base for gPV fuse-link 2XL and 3L with touch safe protection

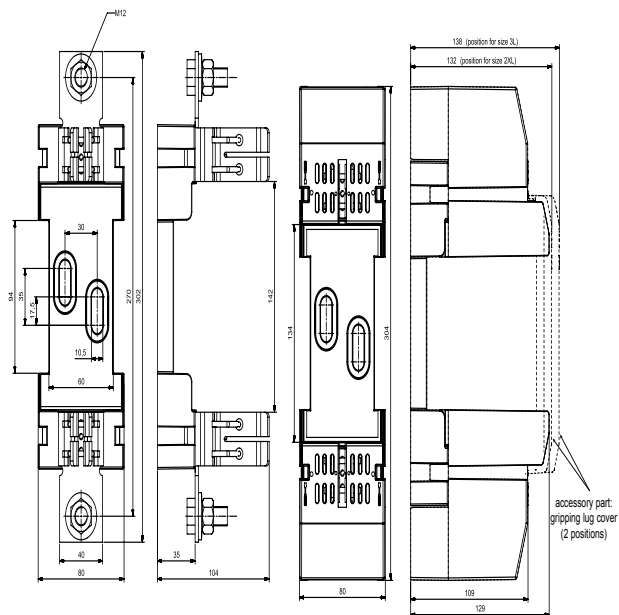

Dimensions in mm

HIGH SPEED FUSES FOR AC AND DC PROTECTION

Protistor® high speed fuse-links Square body fuses size 3x and 7x

Mersen's Semiconductor (Protection) Square Body fuses provide maximum flexibility in equipment design and ultimate protection for today's power conversion equipment such as PV inverters. These square body fuses are available in four different body sizes, each size having seven worldwide acceptable mounting styles. Protistor® fuses have been engineered to provide state-of-the-art protection. They have pure silver or bimetal die-cut elements embedded in solidified sand, which helps control arcing characteristics for low I²t and high interrupting rating. All contact surfaces are silver plated and all hardware is non-magnetic.



SIZE/ SERIES	CHARACTERISTIC	RATED CURRENT (A)	RATED VOLTAGE (V) IEC/UL		RATED BREAKING CAPACITY		MOUNTING
			AC	DC	AC	DC	
30 31 32 33 2x31 2x32	aR	50-2500** 2X up to 5000	690/ 700VAC*	600VDC*	200kA*	100kA*	Flush-end, PressPack
30 31 32 33							Blade
70 71 72 73 2x72 2x73	aR	50-1800** 2X up to 3600	1250/ 1300VAC	750VDC- 1100VDC*			Flush-end, PressPack
70 71 72 73							Blade
70 71 72 73	gR	50-1000	690VAC	600VDC*	150kA	Flush-end, Blade	

* May vary by rating – Consult Mersen technical support

** May vary by mounting

Fuse holders available – Contact Mersen for more information

Ratings:

- **Volts:** See chart
- **Amps:** See chart
- **IR:** See chart

Features/Benefits:

- Extremely fast-acting
- Current limiting
- Very low I²t
- Worldwide acceptability
- Superior cycling ability

Applications:

- Rectifiers
- Inverters
- AC drives
- UPS systems

Approvals:

- UL recognized file E76491
- CSA certified
- IEC 60269-4 certified
- CCC approved



HIGH SPEED FUSES FOR AC AND DC PROTECTION

Protistor® high speed fuse-links

Square body fuses size 70 and 72 aR
1200VDC / 1500VDC* (IEC)

Mersen DC offers provide a very high performant protection for DC protection applications. Mersen DC Semiconductor fuse-links were developed to provide improved performance required by today's new DC equipment. These fuse-links are typically operated at more elevated temperature than other fuse type, have lower I^2t to minimize damage to protected components on short circuits, lower watts loss and longer life.



SIZE/SERIES	OPERATING CLASS/RANGE	AMPERE RATING I_N (A)	RATED VOLTAGE (V) IEC	WEIGHT (KG)	PACKAGE
			DC		
70	aR	20-125	1200VDC / 1500VDC*	0.68	1
72	aR	160-420	1200VDC / 1500VDC*	1.15	1

NEW * 20A-215A, @1500VDC, L/R 1-3ms, 100KA
* 160A-420A, @1500VDC, L/R 1-3ms, 100KA

Features/Benefits:

- Extremely fast acting
- Excellent cycling capability
- Very low I^2t
- Worldwide acceptability
- Current Limiting
- Superior Cycling Ability

Applications:

- Protection of inverters
- Protection of motor drives
- Protection of UPS systems
- Railway power and auxiliary circuits
- ESS Battery Rack protection up to 1500 VDC

Approvals:

- IEC 60269-1 and IEC 60269-4 Compliance
- DC UL recognized component UL file E76491
 - 20A-215A, @1200VDC, L/R 10ms, 100KA
 - 160A-420A, @1200VDC, L/R 10ms, 100KA



1SC Modular Semiconductor Fuse Block



Mersen 1SC semiconductor fuse blocks feature modular mounting that offers greater flexibility in adjusting to various fuse lengths. These semiconductor fuse blocks in stud type version are offered to allow for user preference of wire terminations. The integral box connector versions also provide for greater heat dissipation. Mounting hardware is supplied with the blocks.



Ratings:

- 1000VAC/DC
1500VAC/DC
800A max.

Approvals:

- UL
Recognized
Component

CATALOG NUMBER	MAXIMUM VOLTAGE RATING*	AMPERE RATING	PKG.	UR	CONNECTOR		HARDWARE		TIGHTNING TORQUE (LB.-IN.)			*FIG.
					TYPE	WIRE RANGE	BOLT	WASHER	CABLE	FUSE	MOUNTING	
1SC250	1500	400	Pair	Yes	1/4" Stud	—	—	—	60	60	25	1
1SC375	1500	800	Pair	Yes	3/8" Stud	—	—	—	190	190	50	2
1SCM8	1500	400	Pair	Yes	M8 Stud	—	—	—	60	60	25	1
1SCM10	1500	800	Pair	Yes	M10 Stud	—	—	—	190	190	50	2

For 1SC, order quantity 1 to receive 1 pair.

*Voltage rating applies to AC and DC.

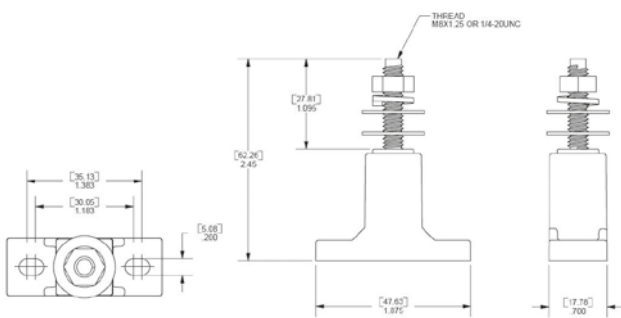

Figure 1

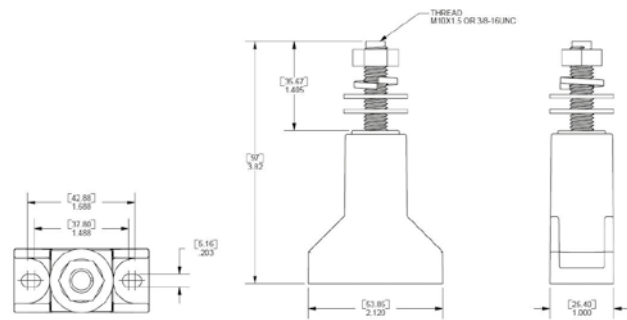

Figure 2

SEMICONDUCTOR FUSES AC+DC FERRULE FUSE HOLDERS PS 20 X 127

Fuse holders and fuse disconnectors for ferrule-type fuses 20x127



Features/Benefits:

- Solid assembly offering good thermal and mechanical withstands
- Fuse mounting in holders or disconnectors with or without preinsulating and blown-fuse indicating microswitches
- Available in 1, 2, 3 and 4 poles

Applications:

- Phenolic resin models for basic applications fiber-glass polyester for applications in corrosive atmospheres or in traction
- $U_i = 1,500\text{ V}$ and $2,500\text{ V}$

DESIGNATION	INSULATION VOLTAGE RATING UI AC 50/60 HZ OR DC	FUSE CURRENT RATING IN (A)	1000V GLB	=1000V GRC	AC1000V GRB	AC1500V GRB	AC1500V GRD	ADVISED COPPER WIRE SIZE MM ²	FIRE AND FUMES CLASS
PSI 20x127	1500V without terminal covers 2500V with terminal covers and only salt spray-proof model	50		50	No operating limit			10	Basic model UL 94 V1 salt spray-proof model UL 94 V0
PSI 20x127 PRE		63		56				16	
PSII 20x127 PRE		80	80					25	
PSIII 20x127 PRE		100	90					35	
PSIV 20x127 PRE		125	100					50	

Connecting with 50 mm² max. cable with copper terminals or with a 15 x 8 max. rigid or flexible bar.

QUANTITY OF POLES	A	B
1	35	50
2	69	84
3	103	118
4	137	152

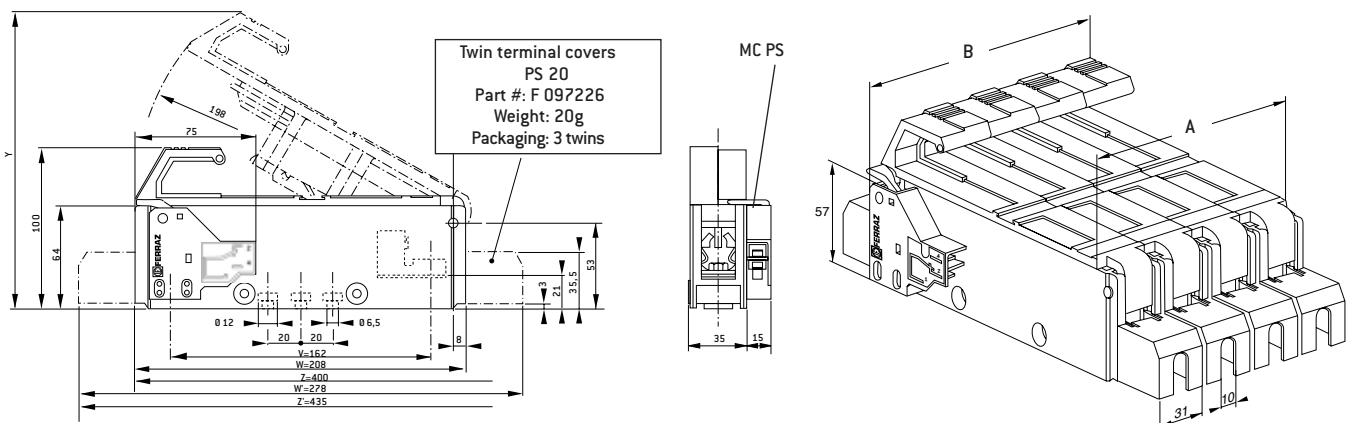

PHOTOVOLTAIC FUSES FOR AC PROTECTION

HelioProtection® Fuse-link NH NH gR 800VAC

800 VAC
READY



Mersen NH fuse-links 800VAC were engineered and designed specifically for photovoltaic systems. gR types are full range breaking capacity fuse-links and are used to protect cables and equipment. They can interrupt any surge, from the lowest fusing up to their breaking capacity, and so can be used alone as protection. They are the perfect solution of protection when used with DC/800VAC Solar inverters.

This fuse range is offered along with Mersen 800VAC Fuse-switch-disconnectors, for a complete fuse-system protection.



Ratings:

- 800VAC
- IR = 90kA
- From 50A to 250A

Approvals:

- IEC 60269-4
- RoHS compliance

Features/Benefits:

- Low fault current interrupting capability
- Temperature cycle withstand capability
- Durable construction for enhanced system longevity
- High efficiency with low power losses
- Available in two versions: Plain Blade & Direct Mounting

Applications:

- General purpose cable and line protection at 800VAC
- Solar installation AC combiner box



PLAIN BLADE		DIRECT MOUNTING		RATED CURRENT I _n	PRE-ARCING I ² T	CLEARING I ² T AT RATED VOLTAGE	POWER DISSIPATION AT I _n	POWER DISSIPATION AT 0.7xI _n	WIDTH (MM)	PACKAGE	WEIGHT (KG)
CATALOG NUMBER	ITEM NUMBER	CATALOG NUMBER	ITEM NUMBER								
NH1GR80V50	R1069101	NH1GR80V50B	H1069093	50 A	0.65 kA ² s	7.76 kA ² s	11 W	4.6 W	39.5	3	0.4
NH1GR80V63	S1069102	NH1GR80V63B	J1069094	63 A	1.46 kA ² s	14.95 kA ² s	13 W	5.4 W	39.5	3	0.4
NH1GR80V80	T1069103	NH1GR80V80B	K1069095	80 A	2.59 kA ² s	24.3 kA ² s	15 W	6.1 W	39.5	3	0.4
NH1GR80V100	V1069104	NH1GR80V100B	L1069096	100 A	4.61 kA ² s	39.2 kA ² s	17 W	7.2 W	39.5	3	0.4
NH1GR80V125	X1069106	NH1GR80V125B	M1069097	125 A	10.37 kA ² s	79.1 kA ² s	18 W	7.4 W	39.5	3	0.4
NH1GR80V160	Y1069107	NH1GR80V160B	N1069098	160 A	20 kA ² s	134.5 kA ² s	23 W	9.6 W	39.5	3	0.4
NH2GR80V200	Z1069108	NH2GR80V200B	P1069099	200 A	64.8 kA ² s	234 kA ² s	27 W	11.3 W	51	3	0.7
NH2GR80V250	A1069109	NH2GR80V250B	Q1069100	250 A	36.45 kA ² s	400 kA ² s	31 W	12.9 W	51	3	0.7

Plain blade dimensions (mm)

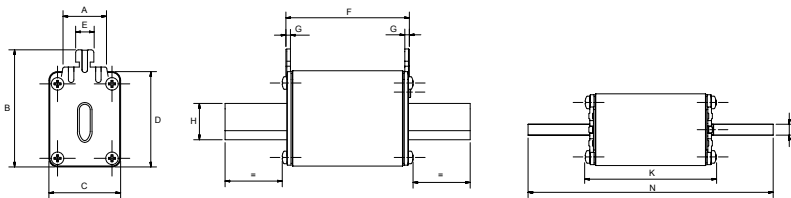

Direct mounting dimensions (mm)

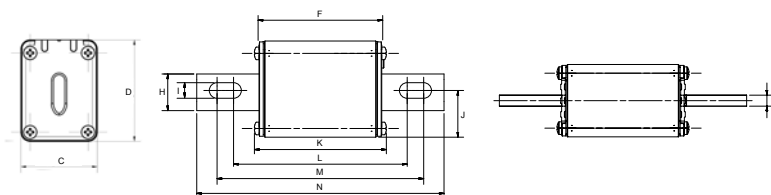

		A	B	C	D	E	F	G	H	I	J	K	L	M	N	O
PLAIN BLADE	NH1	24	64.5	39.5	52.5	10	68	2.5	20	-	-	72.1	-	-	135	6
	NH2	24	72	51	60	10	68	2.5	26	-	-	72	-	-	150	6
DIRECT MOUNTING	NH1	-	-	39.5	-	-	68	-	20	8.5	25.5	-	99.8	117.8	150	6
	NH2	-	-	51	60	-	68	-	26	10.5	27	72	99.8	117.8	150	6

NH VERTICAL FUSE SWITCH DISCONNECTOR

Multivert® 800V Size 1, 160A, 800VAC



Multivert® NH vertical fuse switch disconnectors meet all functions of NH fuse switch disconnectors. They are designed for installation on to bus bars in triple pole arrangements.

Multivert® 800Vac range includes Size 1 Multivert rated at 160A and answers the specific needs of Photovoltaic application for using String inverters rated at 800Vac.

Multivert® 800Vac are used for installation on to 185mm bus bar systems.

Multivert® 800Vac are designed for NH fuse-links Size 1 in accordance with IEC/EN 60269, offered by Mersen for a complete fuse-system protection.

The system is a modular system, that allows the installation of the individual components.

Multivert® offer the user the possibility of fast and easy installation as well as a high degree of protection during installation and maintenance.



Ratings:

- 800VAC
- 160A

Approvals:

- IEC/EN 60947-3
For NH-fuse links size 1 in accordance with IEC/EN 60269
- Mounting on busbar system 185mm
1 x triple pole,
3 x single pole

1 X TRIPLE POLE SWITCHING			3 X SINGLE POLE SWITCHING			CABLE TERMINATION COMPONENTS	PACKAGE
CATALOG NUMBER	ITEM NUMBER	WEIGHT	CATALOG NUMBER	ITEM NUMBER	WEIGHT		
8.150.000	L1069372	4.67 kg	8.100.000	H1069369	4.52 kg	3 M10 bolts	1 piece
8.160.000	M1069373	4.63 kg	8.110.000	J1069370	4.63 kg	3 M10 insert nuts	1 piece
8.170.000	N1069374	4.55 kg	8.120.000	K1069371	4.38 kg	V-terminal for V-terminal clamps size 1,2,3	1 piece

Multivert® Size 1 NH-vertical fuse switch disconnecter, 3 x single pole switching direct installation with screws on to 185mm bus bar system

Multivert® Size 1 NH-vertical fuse switch disconnecter, 1 x triple pole switching direct installation with screws on to 185mm bus bar system

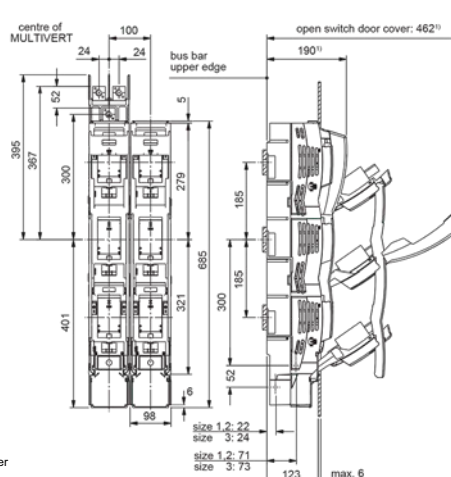
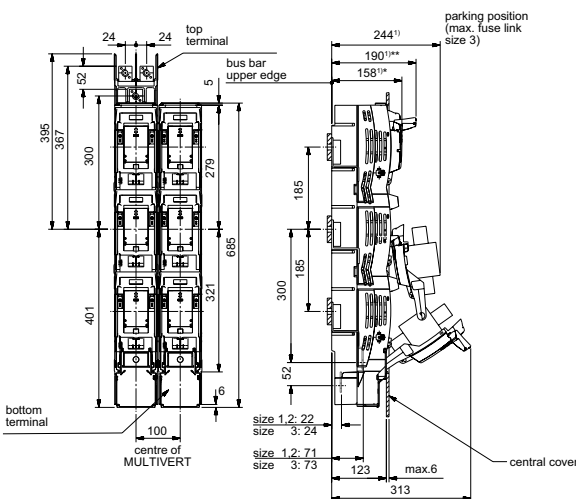

1) dimension from upper edge of bus bar

* 158 mm handle in closed position (folded) = total installation depth of MULTIVERT
** 190 mm handle in open position (fixed) = switching position

Features/Benefits:

- Installation on to 185mm bus bar system
Standard design with M 12 screws: M = 35 33Nm
Direct installation without drilling with hooked clamps possible
- Symmetrical switch - top/bottom cable terminal connection
- Touch protection IP 30 with central cover
- Varieties of cable termination: bolt, insert nut, V-terminal
Other terminations on demand
- Safe on load connection/disconnection in accordance with IEC 60947-3

Applications:

- Power distribution and Motor protection
- Photovoltaic application: Protection on lines of String inverters rated at 800Vac

NH HORIZONTAL FUSE SWITCH DISCONNECTOR

Multibloc® 800V

Size 1, 160A, Design for Bottom Fitting, 3-pole
 Size 2, 250A, Design for Bottom Fitting, 3-pole



The production programme of MULTIBLOC® 800VAC comprises NH fuse switch disconnectors for 800VAC voltage application. This range includes Size 1 (1.ST8) and Size 2 (2.ST8) Multibloc and answers the specific needs of Photovoltaic application for using String inverters rated at 800Vac.

They are designed for bottom fitting/panel installation and are available in triple pole units.

For installation of MULTIBLOC® NH fuse switch disconnectors in distribution units with central cover, respective covers are used to obtain a uniform profile in height and length.

Multibloc® size 1 and size 2 are designed for NH fuse-links in accordance with IEC/EN 60269, size 1 and size 2, 160A and 250A, offered by Mersen for a complete fuse-system protection.

Multibloc® offers the user the possibility of fast and easy installation as well as a high degree of security during installation and maintenance.



Ratings:

- 800VAC
- 160A, 250A

Approvals:

- IEC/EN 60 947-3
 For NH-fuse links size 1 and size 2 in accordance with IEC/EN 60 269,
 Mounting:
 bottom fitting/panel
 3-pole switching

Multibloc® 1.ST8 size 1 160A, 800VAC bottom fitting, triple pole

CATALOG NUMBER	ITEM NUMBER	POLES	CABLE TERMINATION COMPONENTS	PACKAGE	WEIGHT
8.000.299	B1069363	3	6 M10 terminal screws	1 piece	2.42 kg
8.001.239	C1069364	3	3 clamp straps 70–150 mm ² 3 M10 terminal screws	1 piece	2.42 kg
8.002.562	D1069365	3	6 clamp straps 70-150 mm ²	1 piece	2.42 kg

Multibloc® 2.ST8 size 2 250A, 800VAC bottom fitting, triple pole

CATALOG NUMBER	ITEM NUMBER	POLES	CABLE TERMINATION COMPONENTS	PACKAGE	WEIGHT
8.000.504	E1069366	3	6 M10 terminal screws	1 piece	3.5 kg
8.001.240	F1069367	3	3 clamp straps 120–240 mm ² 3 M10 terminal screws	1 piece	3.5 kg
8.002.563	G1069368	3	6 clamp straps 120–240 mm ²	1 piece	3.5 kg

Multibloc® 800 VAC NH-fuse switch disconnecter Size 1, triple pole design for bottom fitting

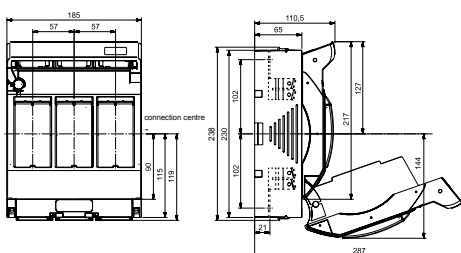

Multibloc® 800 VAC NH-fuse switch disconnecter Size 2, triple pole design for bottom fitting

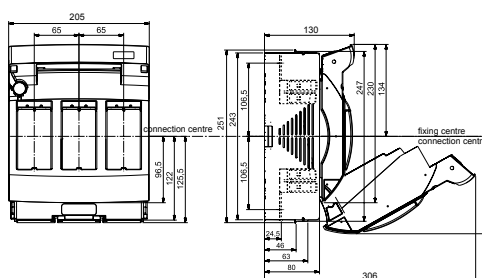

Features/Benefits:

- Touch protection IP 20 - when fuse link is in test mode IP rating is maintained
- Parking position of switch operating cover even with fuse-links inserted
- Modular system of cover - cover for cable termination area can be extended as required
- Varieties of cable termination: screw, bolt, clamp strap, extendable for V-terminal - optional
- Padlocking and sealing of switch door cover - optional
- Indicating switch for switch door position - optional
- Installation on to DIN rails in accordance with EN 60 715 - optional
- Safe on load connection/disconnection in accordance with IEC 60947-3

Applications:

- Power distribution and Motor protection
- Photovoltaic application: Protection on lines of String inverters rated at 800Vac

CONVERTER PROTECTION – CYLINDRICAL AUXILIARY DC FUSE

Protistor® cylindrical auxiliary DC fuse

Mersen DC high performance power fuses were developed to provide superior protection for railway power and auxiliary circuits. They have lower I²t to minimize damage to components in case of short circuits, and have lower watts loss and longer life.



SIZE/SERIES	OPERATING CLASS/RANGE	AMPERE RATING I _N (A)	RATED VOLTAGE (VDC) IEC/UL	MAXIMUM INTERRUPTING RATING IR	MOUNTING
			DC	DC	
20X127 mm	gR	6-63	1000VDC	100kA	Ferrule
		0,8-25	1500VDC	30kA	

Fuse holders available – Contact Mersen for more information

Features/Benefits:

- Extremely fast acting
- Current limiting
- Very Low I²t
- Worldwide acceptability
- Superior cycling ability

Applications:

- Protection of rectifiers,
- inverters, DC drives, Traction
- Auxiliary Circuits
- UPS Systems, reduced voltage motor starters, and other equipment in globally accepted applications

Approvals:

- UL Recognized file E76491
- IEC 60269-4 compliance

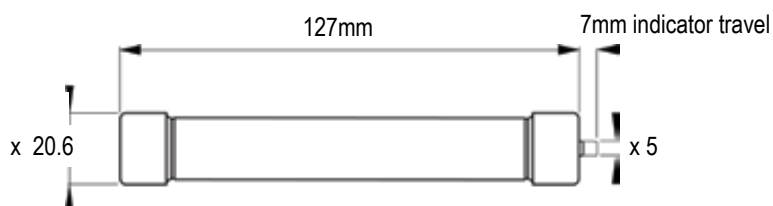
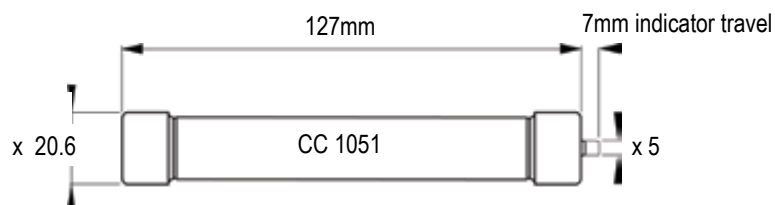

DISCONNECT SWITCHES FOR PHOTOVOLTAIC APPLICATIONS

PV-Rated Disconnect Switches

Mersen launches a global line of premium compact low voltage switchgear

PV-rated Switches

100A to 500A Up to 1000VDC

Mersen offers a range of DC disconnect switches specially designed for PV applications, in 2 poles and 2x2 poles configurations for double circuit applications. The technology inside the switch and the visible contacts allow a quick, safe, and reliable DC breaking power at all current levels up to 1500VDC. The product is ready and simple to install independently of the polarity, with very limited power losses, and with a 40% smaller footprint than competition. The 1000V versions have 2 switching modules (poles) and the 1500V versions have 3 modules.

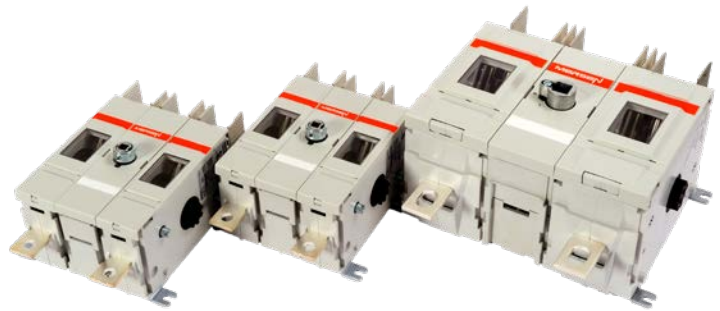

Function

Standard switch-disconnect provides the load break switching function: making, carrying, breaking current plus isolation.

Applications:

2-pole PV-rated switches disconnect individual strings, individual arrays and PV inverter from the DC side.

Features

- **Safety:**
Robust design, visible contacts, user-independent operation
- **Performance:**
Specifically designed for DC applications: dual magnetic breaking
- **Size:**
40% to 57% smaller footprint = greatly reduced installation area
- **Flexibility in installation:**
Symmetrical power-pole design independent of polarity
- **Flexibility in logistics:**
Ordering process and stock control is more fluent due to reduced part numbers
- **Environmental impact:**
No harmful material

Versions and accessories

- Extended shaft
- Pistol type handle
- Direct mounting type handle
- Auxiliary contact
- Module for auxiliary contact
- Mechanical and electrical interlock
- Terminal clamp
- Short-circuit link
- Terminal shroud

DISCONNECT SWITCHES FOR PHOTOVOLTAIC APPLICATIONS

PV-Rated Disconnect Switches IEC-Rated DC Switches



MD100E11



MD100E22

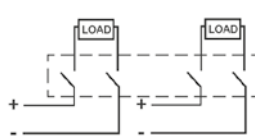
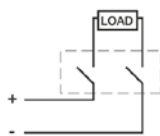

Switch Body

AMPERE RATING	100	160	200	250
1000VDC 2-pole Configuration	MD100E11	MD160E11	MD200E11	MD250E11
1000VDC 2x2-pole Configuration	MD100E22	MD160E22	MD200E22	MD250E22

DIRECT FRONT OPERATION

	HDD250	HDD250	HDD250	HDD250
--	--------	--------	--------	--------

Handles and Shafts

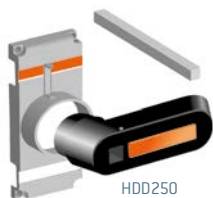

HDD250



HB65

EXTERNAL PISTOL STYLE

NEMA Type 1, 3R, 12	HB65, HB80
NEMA Type 4, 4X	HB65X, HB80X

B=Black. Substitute 'R' for 'B' if a red handle is desired. Ex. HR65

SHAFTS

Shaft—SPAxxx (xxx = length in mm)	SPA130, SPA210, SPA290, SPA360, SPA430
--------------------------------------	--

AUXILIARY CONTACTS*

NO Right side mounting	OA1G10	OA1G10	OA1G10	OA1G10
NC left side mounting	OA3G01	OA3G01	OA3G01	OA3G01
Module for SF aux. contacts	OEA28	OEA28	OEA28	OEA28

*Rated 2A max continuous @690VAC

Accessories



OA1G01
OA1G10



OEA28



JUMP250 JC250

SHORT CIRCUIT LINK

For MDxxxE22 and EV33				
For MDxxxE11, E22, EV12**	JUMP250	JUMP250	JUMP250	JUMP250

**Shipped with one link per circuit

TERMINAL SHROUD FOR SHORT CIRCUIT LINK

For JUMP500-2				
For JUMP250, JUMP500	JC250	JC250	JC250	JC250

TERMINAL SHROUDS FOR LUGS

Kit of 4 Terminal Shrouds	TS250-14	TS250-14	TS250-14	TS250-14
1 Terminal Shroud				

A shorter version is available for DC Switches up to 250A. 1 piece per package: TDS250S

DISCONNECT SWITCHES FOR PHOTOVOLTAIC APPLICATIONS

PV-Rated Disconnect Switches UL 98B Listed DC Switches



MD100U11



MD100U22

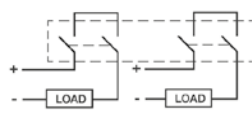
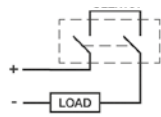

Switch Body

AMPERE RATING	100	200
1000VDC 2-pole Configuration	MD100U11	MD200U11
1000VDC 2x2-pole Configuration	MD180U22	MD180U22
1500VDC 2-pole Configuration		

Handles and Shafts

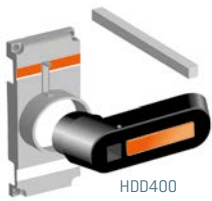

HDD400



HB125

DIRECT FRONT OPERATION		
1000VDC	HDD250	HDD250
1500VDC		

EXTERNAL PISTOL STYLE		
NEMA Type 1, 3R, 12	HB65, HB80	
NEMA Type 4, 4X	HB65X, HB80X	

B=Black. Substitute 'R' for 'B' if a red handle is desired. Ex. HR65

SHAFTS		
Shaft—SPAxxx (xxx = length in mm), SFBxxx (xxx = length in mm)	SPA130, SPA210, SPA290, SPA360, SPA430	

Accessories



OA1G01
OA1G10



OEA28



JC250

AUXILIARY CONTACTS*		
NO Right side mounting	OA1G10	OA1G10
NC left side mounting	OA3G01	OA3G01
Module for SF aux. contacts	OEA28	OEA28

*Rated 2A max continuous @690VAC

TERMINAL SHROUD FOR SHORT CIRCUIT LINK		
For MDxxxU11, UV12	JC250	JC250
For MDxxxU22	JC500-2	JC500-2

TERMINAL SHROUD FOR LUGS		
Kit of 4 Terminal Shrouds		
1 Terminal Shroud	TDS400	TDS400

A shorter version is available for DC switches up to 250A. 1 piece per package: TDS250S.

DISCONNECT SWITCHES FOR PHOTOVOLTAIC APPLICATIONS

PV-Rated Disconnect Switches

UL 98B DC-rated Non-Fused switches

PART #	DESCRIPTION	REF #
MD100U11	DC Switch 100A UL 2p	X1043231
MD180U22	DC Switch 180A UL 4p	Y1043232
MD200U11	DC Switch 200A UL 2p	Z1043233

IEC DC-rated Non-Fused switches

PART #	DESCRIPTION	REF #
MD100E11	DC Switch 100A IEC 1000V 2p	G1043217
MD160E11	DC Switch 160A IEC 1000V 2p	H1043218
MD200E11	DC Switch 200A IEC 1000V 2p	J1043219
MD250E11	DC Switch 250A IEC 1000V 2p	K1043220
MD100E22	DC Switch 100A IEC 2x1000V 4p	L1043221
MD160E22	DC Switch 160A IEC 2x1000V 4p	M1043222
MD200E22	DC Switch 200A IEC 2x1000V 4p	N1043223
MD250E22	DC Switch 250A IEC 2x1000V 4p	P1043224

Handles

PART #	DESCRIPTION	REF #
HB65	Handle black 65mm IP65 NEMA 3R	W1043368
HB65X	Handle black 65mm IP65 NEMA 4X	X1043369
HR65	Handle red 65mm IP65 NEMA 3R	G1043378
HR65X	Handle red 65mm IP65 NEMA 4X	H1043379
HDD250	Handle direct MD100-250	G1047794

Shafts

PART #	DESCRIPTION	REF #
SPA130	Shaft pistol handle 6x6x130mm	V1043919
SPA210	Shaft pistol handle 6x6x210mm	P1043431
SPA290	Shaft pistol handle 6x6x290mm	Q1043432
SPA360	Shaft pistol handle 6x6x360mm	W1043920
SPA430	Shaft pistol handle 6x6x430mm	X1043921

Terminal Shrouds

PART #	DESCRIPTION	REF #
TS250-14	Term.shrd 250A switch 1p L/4	A1043464

Jumpers

PART #	DESCRIPTION	REF #
JUMP250	Jumper bar for 250A DC switch	F1043469
JC250	Jumper cover for JUMP250	H1043471

DIN-RAIL PLUG-IN SPDs



Type 1+2 and Type 2

SPDs to EN 50539-11,
IEC/EN 61643-31

1500VDC
READY



No back-up fuse required

Mersen has developed an optimised dynamic thermal disconnection system, which does not require back-up fuse



Multiple MPPT inverter

Protection with multipole DC SPDs



UL 1449 4th Ed
EN-50539-11
ROHS



Tested and certified

Mersen's highly specialized test labs for PV product development

Ucpv [Vdc]
65
80
660
720
1060
1500

Wide voltage range

Ucpv up to 1500 Vdc

PCB PLUG-IN SPDs

1500VDC
READY

Up to 1500 VDC

Air clearance & creepage distances meet requirements of all applications (AC and DC)

Remote indication

Cartridge presence
End-of-life



Single-pole sockets

For all system configurations on PCBs
Also fault-resistant Y-circuits (PV or AC)

Optimal voltage protection level

Integration at early stage of PCB development

- Close to sensitive electronics
- No cable lengths

Cost & space efficiency

- No wiring, wave soldered surge protection
- Space saving solution



T1 & T2 surge protection

Mechanical forces of Type 1 & 2 discharges won't loosen the protection cartridges

Firmly fixed

Vibration-proof surge cartridges
Easy cartridge replacement

Mechanical coding

Safety system to avoid insertion of wrong voltage rated cartridge

OEM manufacturers

- Inverters, converters, UPS
- Railway power & control panels
- PV Combiner boxes
- OEM-machines



Lite version

- Small footprint, socket-free assembly (direct PCB mounting)
- 10kA In and 25kA Imax Type 2 IEC/UL, up to 1500Vdc

SURGE-TRAP® DC TYPE 1+2 YPV PHOTOVOLTAIC SPD

STP T12 5 YPV

STP T12 5 YPV is the PHOTOVOLTAIC range of combined Type 1+2/Class I+II devices intended for discharging lightning currents (10/350 μ s) and protecting against induced voltage surges (8/20 μ s), in accordance with EN 50539-11 and IEC/EN 61643-31 standards.

Mersen uses its dynamic thermal disconnection system with high breaking capacity, optimised for DC voltages. This means there is no need to install a backup fuse to interrupt the typical short-circuit currents of any photovoltaic installation.

These lightning current and surge protection devices are suitable for all photovoltaic applications: large-scale, rooftop and self-consumption (off-grid) DC installations; especially in facilities provided with external LPS.

Ratings and features

- Lightning impulse current (10/350 μ s): 5 kA
- Maximum discharge current (8/20 μ s): 40 kA
- Nominal discharge current (8/20 μ s): 20 kA
- Ucpv: 1060 Vdc and 1500 Vdc
- Iscpv: 10 kA (EN 50539-11), no back-up fuse required
- Plug-in DIN rail format
- Visual and remote end of life indication
- Reversible chassis to allow cable entry from above or below
- Mechanically coded cartridges to avoid replacement errors

Catalog numbers / Reference numbers

REFERENCE NUMBER	CATALOG NUMBER	Network									Cartridge Id.
		SYSTEM TYPE	ELECTRICAL DIAGRAM	UCPV [VDC]	ISCPV [A]	IIMP (10/350) [KA]	IMAX (8/20) [KA]	IN (8/20) [KA]	UP@IN (8/20) [KV]	REMOTE INDICATION (M)	
83120167	STPT12-5K1000V-YPV	"Y" PV	A	1060	10 000	5	40	20	≤ 4		C43
83120168	STPT12-5K1000V-YPVM	"Y" PV	A	1060	10 000	5	40	20	≤ 4	√	C43
83120193	STPT12-5K1500V-YPV	"Y" PV	A	1500	10 000	5	40	20	≤ 5		C44
83120194	STPT12-5K1500V-YPVM	"Y" PV	A	1500	10 000	5	40	20	≤ 5	√	C44

Replacement cartridges

REF. NUMBER	CATALOG NUMBER	NETWORK	UCPV [VDC]	IIMP (10/350) [KA]	IMAX (8/20) [KA]	IN (8/20) @ UP [KA]	UP@IN (8/20) [KV]	CARTRIDGE ID.
83120011	SP12-5K1000V-PV	PV	530	5	40	20	≤ 2	C43
83120023	SP12-5K1500V-PV	PV	750	5	40	20	≤ 2,5	C44

Microswitch diagram

	U _{max} / I _{max}	
	AC: 250 V/1 A	
	AC: 125 V/3 A	

Dimensions

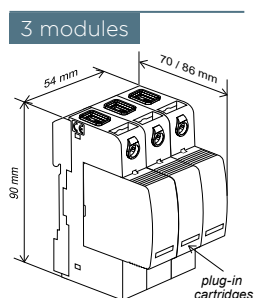

Electrical diagram

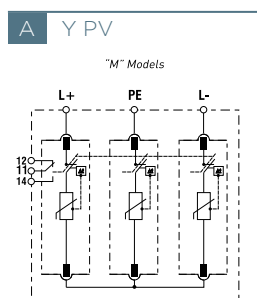

limp

5kA

LEARN MORE

ep.mersen.com

No back-up fuse required

Approvals/Standards

- EN 50539-11
- IEC/EN 61643-31
- UL 1449 4th Ed recognized, File No. E468946
- CE

SURGE-TRAP® DC TYPE 2 YPV PHOTOVOLTAIC SPD

STP T2 40 YPV

STP T2 40 YPV is the series of Type 2/Class II devices for discharging voltage surges in PV systems. This series provides advanced overvoltage protection by utilizing Mersen's optimized dynamic thermal disconnection system. This system does not require additional overcurrent protection (back-up fuse) due to its high short-circuit withstand rating.

Ratings and features

- Maximum discharge current (8/20µs): 40kA
- Nominal discharge current (8/20µs): 20kA
- Ucpv: 65, 80, 660, 1060 Vdc and 1500Vdc
- Iscpv: 10kA (EN 50539-11), no back-up fuse required
- SCCR: 50-100kA (UL 1449 4th Ed)
- DIN-rail mountable, plug-in format
- Visual and remote end of life indicators
- Reversible chassis to allow cable entry from above or below
- Mechanically coded cartridges to avoid cartridge replacement errors

Imax

40kA

No back-up fuse required

LEARN MORE

ep.mersen.com

Approvals/Standards

- EN 50539-11
- IEC 61643-31
- UL 1449 4th Ed recognized, File No. E468946
- CE

Catalog numbers / Reference numbers

REFERENCE NUMBER	CATALOG NUMBER	Network								Cartridge Id.
		SYSTEM TYPE	ELECTRICAL DIAGRAM	UCPV [VDC]	ISCPV [A]	IMAX (8/20) [KA]	IN (8/20) [KA]	UP@IN (8/20) [KV]	REMOTE INDICATION (M)	
Y PV. LARGE-SCALE AND ROOFTOP PV										
83020138	STPT2-40K600V-YPV	"Y" PV	A	660	10 000	40	20	≤2.6		C40
83020139	STPT2-40K600V-YPVM	"Y" PV	A	660	10 000	40	20	≤2.6	✓	C40
83020140	STPT2-40K1000V-YPV	"Y" PV	A	1060	10 000	40	20	≤4		C41
83020141	STPT2-40K1000V-YPVM	"Y" PV	A	1060	10 000	40	20	≤4	✓	C41
83020158	STPT2-40K1500V-YPV	"Y" PV	A	1500	10 000	40	15	≤5		C42
83020159	STPT2-40K1500V-YPVM	"Y" PV	A	1500	10 000	40	15	≤5	✓	C42
U PV. SELF-CONSUMPTION										
83020128	STPT2-40K60V-2P	TNS (1Ph+N); PV	B	65	1000	40	20	≤0.7		Consult
83020129	STPT2-40K60V-2PM	TNS (1Ph+N); PV	B	65	1000	40	20	≤0.7	✓	Consult
83020130	STPT2-40K75V-2P	TNS (1Ph+N); PV	B	80	1000	40	20	≤0.8		Consult
83020131	STPT2-40K75V-2PM	TNS (1Ph+N); PV	B	80	1000	40	20	≤0.8	✓	Consult

Replacement cartridges

REF. NUMBER	CATALOG NUMBER	NETWORK	UCPV [VDC]	IMAX (8/20) [KA]	IN (8/20) @UP [KA]	UP@IN (8/20) [KV]	CARTRIDGE ID.
83020005	SP2-40K600V-PV	PV	330	40	20	≤1.3	C40
83020006	SP2-40K1000V-PV	PV	530	40	20	≤2	C41
83020010	SP2-40K1500V-PV	PV	750	40	10	≤2,5	C42

Microswitch diagram

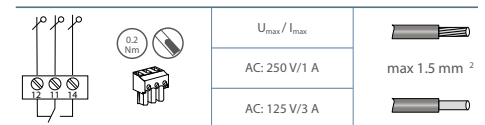

Dimensions

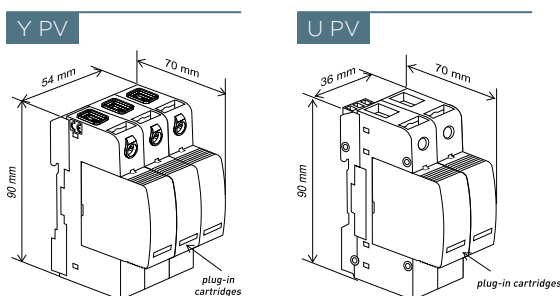

Electrical diagram

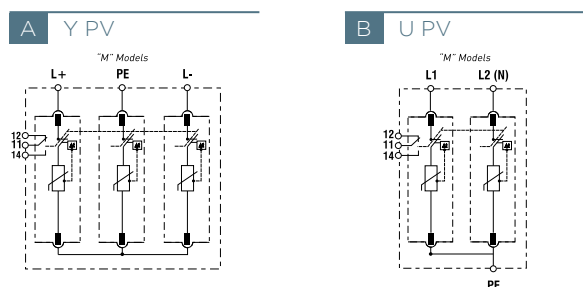

SURGE-TRAP® DC T2 & T1+2 MPPT PHOTOVOLTAIC SPD

STP MPPT PV

STP MPPT PV is the PHOTOVOLTAIC range of combined T1+2 / Class I+II and T2 / Class II devices intended for discharging lightning currents (10/350 μ s) and protecting against induced voltage surges (8/20 μ s), in accordance with EN 50539-11, IEC 61643-31 and UL 1449 (for Type 2).

Mersen uses its dynamic thermal disconnection system with high breaking capacity, optimised for DC voltages. This means there is no need to install a backup fuse to interrupt the typical short-circuit currents of any photovoltaic installation.

The devices are suitable for all PV applications: large-scale and rooftop. Includes specific multipole products for multiple maximum power point tracker (MPPT) inverters.

Ratings and features

- Maximum discharge current (8/20 μ s): 40kA
- Nominal discharge current (8/20 μ s): 20kA
- For Type 1+2, lightning impulse current (10/350 μ s): 5kA
- Ucpv: 1060 Vdc
- Iscpv: 10 kA (EN 50539-11), no back-up fuse required
- Multipole MPPT specific products
- DIN-rail mountable, plug-in format
- Visual and remote end of life indicators
- Reversible chassis to allow cable entry from above or below
- Mechanically coded cartridges to avoid replacement errors

Catalog numbers / Reference numbers

REFERENCE NUMBER	CATALOG NUMBER	Network									Cartridge Id.
		SYSTEM TYPE	ELECTRICAL DIAGRAM	UCPV [VDC]	ISCPV [A]	IIMP (10/350) [KA]	IMAX (8/20) [KA]	IN (8/20) [KA]	UP@IN (8/20) [KV]	REMOTE INDICATION (M)	
TYPE 1+2											
83120192	STPT12-5K1000V-5YPVM	3+, 1-, 1PE	A	1060	10000	5	40	20	4	√	C43
83120206	STPT12-5K1000V-5Y2PVM	2+, 2-, 1PE	C	1060	10000	5	40	20	4	√	C43
83120190	STPT12-5K1000V-8YPVM	6+, 1-, 1PE	B	1060	10000	5	40	20	4	√	C43
TYPE 2											
83020188	STPT2-40K1000V-5YPVM	3+, 1-, 1PE	A	1060	10000	-	40	20	4	√	C41
83020223	STPT2-40K1000V-5Y2PVM	2+, 2-, 1PE	C	1060	10000	-	40	20	4	√	C41
83020204	STPT2-40K1000V-8YPVM	6+, 1-, 1PE	B	1060	10000	-	40	20	4	√	C41

Replacement cartridges

REF. NUMBER	CATALOG NUMBER	NETWORK	UCPV [VDC]	IIMP (10/350) [KA]	IMAX (8/20) [KA]	IN (8/20) [KA]	UP@IN (8/20) [KV]	CARTRIDGE ID.
83020006	SP2-40K1000V-PV	PV	530	-	40	20	≤2	C41
83020011	SP12-5K1000V-PV	PV	530	5	40	20	≤2	C43

Microswitch diagram

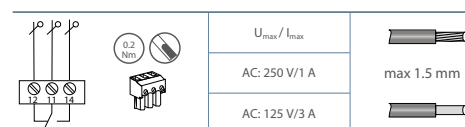

Dimensions

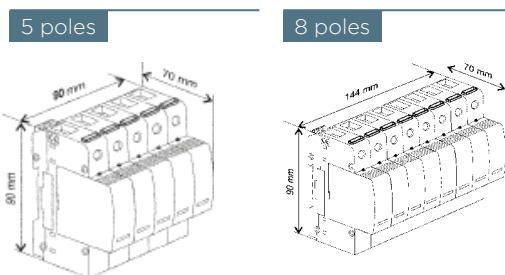

Electrical diagram

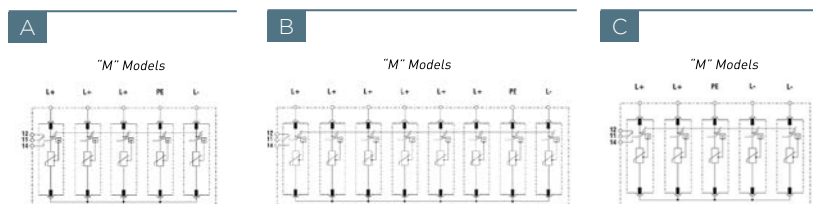

Iimp Imax

5kA **40kA**

[LEARN MORE](#)

ep.mersen.com

No back-up fuse required

Approvals/Standards

- EN 50539-11
- IEC 61643-31
- UL 1449 4th Ed recognized, File No. E468946
- CE

SURGE-TRAP® PV SPD CONNECTION BOXES FOR INVERTERS

PV BOX

PV BOX is the series of DC photovoltaic surge protection connection boxes for inverters to IEC/EN standard.

Such boxes are ready for installation and just need to be connected in parallel upstream of residential and lite commercial string inverters of several MPP trackers, mainly 1000Vdc rooftop installations.

Available in several configurations including Type 1 or Type 2 surge protection with MC4 or cable gland connectors. Please consult for availability and models, for instance 5pole and 8pole SPDs.

Ratings and features

- Pre-assembled junction box with SPDs for 1000VDC
- Quick installation of the DC protection, next to the inverter
- MC4 or cable gland connectors
- 1 or 2 MPPT versions
- 1 or 2 string inputs per MPPT
- Type 1+2 5kA Iimp or Type 2 40kA Imax SPDs
- Visual end of life indicator

Iimp Imax

5kA **40kA**

LEARN MORE

ep.mersen.com

Approvals/Standards

- IEC/EN 61439-12
- IEC/EN 61643-31
- CE

Catalog numbers / Reference numbers

REFERENCE NUMBER	CATALOG NUMBER	DIMENSIONS	SPD REFERENCE	QUANTITY SPD	NUMBER OF MPP	STRINGS PRO MPP	CONNECTOR TYPE
TYPE 1+2							
83070002	PVBT12-1000V-B-113	A	83120167	1	1	1	CABLE GLAND
83070102	PVBT12-1000V-BH-113	A	83120167	1	1	1	MC4
83070006	PVBT12-1000V-B-213	B	83120167	2	2	2	CABLE GLAND
83070106	PVBT12-1000V-BH-213	B	83120167	2	2	2	MC4
TYPE 2							
83070000	PVBT2-1000V-B-113	A	83020140	1	1	1	CABLE GLAND
83070100	PVBT2-1000V-BH-113	A	83020140	1	1	1	MC4
83070004	PVBT2-1000V-B-213	B	83020140	2	2	2	CABLE GLAND
83070104	PVBT2-1000V-BH-213	B	83020140	2	2	2	MC4

Dimensions

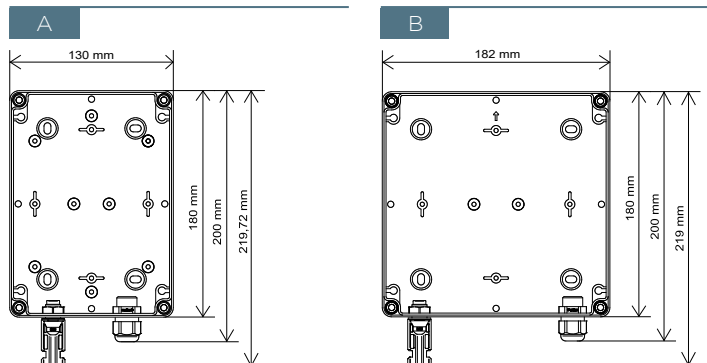

SPD Electrical diagram

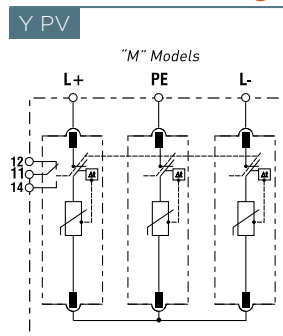

SURGE-TRAP® PCB PLUG-IN OR DIRECT ASSEMBLY

SB-PCB

SB PCB is the series of socket bases that allow for integration of Mersen's pluggable IEC surge protection cartridges directly on printed circuit boards. Those surge cartridges will be easily replaceable upon reaching their end of life.

SB PCB is an optimal solution for the industry of power electronics: inverters, converters, control panels for railway, PV combiner boxes, machines, OEM equipment, etc. Key benefits are cost efficiency, space efficiency, no wiring and optimal voltage protection of sensitive electronics.

Integration of surge protection on PCBs is often planned for at an early stage of development of the system. The surge sockets will be firmly fixed to the PCB during the wave soldering process. They'll host the entire range of IEC surge protection cartridges AC & DC, T2 & T1.

Features

- Single pole sockets. All system configurations on PCBs.
- Up to 1500 VDC
- T1 & T2 surge protection (IEC 61643-11)
- Remote end of life indicator
- Voltage ratings DC: 660 - 1500V_{DC}
- Voltage ratings AC: 60 - 850V_{AC}
- Mechanical coding to avoid cartridge insertion errors
- Vibration proof (EN 60721-3-3)

Benefits

- Cost efficiency
- Space efficiency
- No wiring
- Optimal voltage protection

Catalog numbers / Reference numbers

REFERENCE NUMBER	CATALOG NUMBER	UCPV [VDC]	REMOTE INDICATION (M)	Cartridge Id.	
				REFERENCE NUMBER	CATALOG NUMBER
DC SIDE					
83050133	SB-PCB-1000PV-M	1000	√	83020006	SP2-40K1000V-PV
83050135	SB-PCB-1500PV-M	1500	√	83020010	SP2-40K1500V-PV
AC SIDE					
83050119	SB-PCB-275V-M	275	√	83020002	SP2-40K275V
83050123	SB-PCB-440V-M	440	√	83020004	SP2-40K440V
83050127	SB-PCB-750V-M	750	√	83020007	SP2-30K750V
83050129	SB-PCB-N-M	neutral	√	83020000	SP2-40K-N

limp I_{max}

25kA **80kA**

ep.mersen.com

Approvals/Standards

- IEC/EN 61643-11
- CE

Dimensions

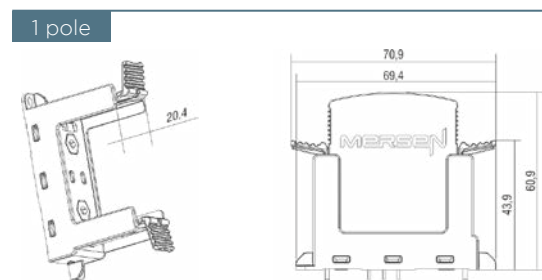

SP-PCB

SP-PCB is the series of surge plugs that allow for both direct and socket assembly of small footprint Type 2 SPD to IEC and UL. Such SPDs perform at 10kA I_n and 25kA I_{max} up to 1500V_{dc}. Consult for further information and the socket option.



Catalog numbers / Reference numbers

REF. NUMBER	CATALOG NUMBER	UCPV [VDC]	I _{MAX} (8/20) [KA]	I _N (8/20) @UP [KA]	UP@I _N (8/20) [KV]
84020013	SP2-10K500V-PV	500	25	10	≤ 1,5
84020014	SP2-10K670V-PV	670	25	10	≤ 1,8
84020016	SP2-10K900V-PV	900	25	10	≤ 2,5

SURGE-TRAP® AC TYPE 1+2 PHOTOVOLTAIC SPD

STP T12 5

STP T12 5 is the series of combined Type 1+2 /Class I+II devices for discharging lightning currents and protecting against voltage surges, in accordance with IEC/EN 61643-11 and UL 1449.

Suitable as the first step of protection for the AC side in photovoltaic systems that supply power to the grid, especially installations which are provided with an external lightning protection system due to their exposure.

The series comprehends specific models for applications where high withstand voltage peaks are required, such as in the case of PV grid side with induced DC offsets or wind turbine generators.

Also suited for first or second stage of protection in commercial or residential applications.

Ratings and features

- Lightning impulse current (10/350µs): 5kA per phase
- Maximum discharge current (8/20µs): 40kA per phase
- Nominal discharge current (8/20µs): 20kA per phase
- TNS, TNC, TT and IT networks
- Un(L-N/L-L): 230/400V, 277/480V, 400/690V & higher
- DIN-rail mountable, plug-in format
- Visual and remote end of life indicators
- Reversible chassis to allow cable entry from above or below
- Mechanically coded cartridges to avoid cartridge replacement errors

Catalog numbers / Reference numbers

REFERENCE NUMBER	CATALOG NUMBER	Network								Cartridge Id.		
		SYSTEM TYPE	ELECTRICAL DIAGRAM	UN [VAC]	UC [V]	IIMP (10/350) [KA]	IMAX (8/20) [KA]	IN (8/20) [KA]	UP@IN (8/20) [KV]	REMOTE INDICATION (M)	L	N
83120238	STPT12-5K320V-1P	L-N (1Ph)	A	277	320	5	40	20	≤1.5		C51	
83120239	STPT12-5K320V-1PM	L-N (1Ph)	A	277	320	5	40	20	≤1.5	√	C51	
83120240	STPT12-25K-N1	N-PE	B	Neutral	277	5	40	20	≤1.5			C53
83120214	STPT12-5K320V-2P	TNS (1Ph+N)	D	277	320	5	40	20	≤1.5		C51	
83120215	STPT12-5K320V-2PM	TNS (1Ph+N)	D	277	320	5	40	20	≤1.5	√	C51	
83120241	STPT12-5K320V-2PG	TT (1Ph+N)	C	277	320	5	40	20	≤1.5 / 1.5		C51	
83120242	STPT12-5K320V-2PGM	TT (1Ph+N)	C	277	320	5	40	20	≤1.5 / 1.5	√	C51	C53
83120202	STPT12-5K320V-3P	TNC (3Ph)	E	-/480	320	5	40	20	≤1.5		C51	C53
83120203	STPT12-5K320V-3PM	TNC (3Ph)	E	-/480	320	5	40	20	≤1.5	√	C51	
83120222	STPT12-5K320V-4P	TNS (3Ph+N)	H	277 / 480	320	5	40	20	≤1.5		C51	
83120223	STPT12-5K320V-4PM	TNS (3Ph+N)	H	277 / 480	320	5	40	20	≤1.5	√	C51	
83120200	STPT12-5K320V-4PG	TT (3Ph+N)	G	277 / 480	320	5	40	20	≤1.5 / 1.5		C51	C53
83120201	STPT12-5K320V-4PGM	TT (3Ph+N)	G	277 / 480	320	5	40	20	≤1.5 / 1.5	√	C51	C53
IT (3PH) - REINFORCED PEAK WITHSTAND												
83120243	STPT12-5K680V-3P-R	IT (3Ph)	F	800	1360	5	40	20	≤5		C52	
83120244	STPT12-5K680V-3P-RM	IT (3Ph)	F	800	1360	5	40	20	≤5	√	C52	

Replacement cartridges

REF. NUMBER	CATALOG NUMBER	NETWORK	UN [VAC]	UC [V]	IMAX (8/20) [KA]	IN (8/20) @UP [KA]	UP@IN (8/20) [KV]	CARTRIDGE ID.
83120020	SP12-5K320V	L-N (1Ph)	277	320	40	20	≤ 1,5	C51
83120015	SP12-25K-N1	N-PE [N]	Neutral	277	40	20	≤ 1,5	C53
83120025	SP12-5K680V	L-N (1Ph)	680	680	40	20	≤ 2,5	C52

Microswitch diagram

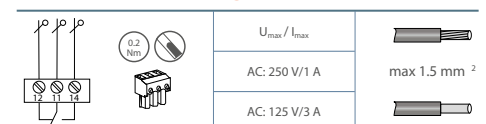

limp
5kA

Approvals/Standards

- IEC/EN 61643-11
- UL 1449 4th Ed recognized, File No. E468946
- CE

SURGE-TRAP® AC TYPE 1+2 PHOTOVOLTAIC SPD

Dimensions

1 pole

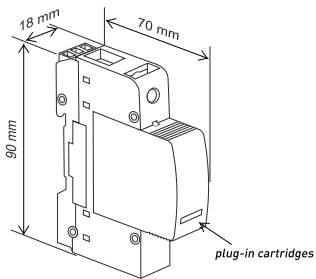

2 poles

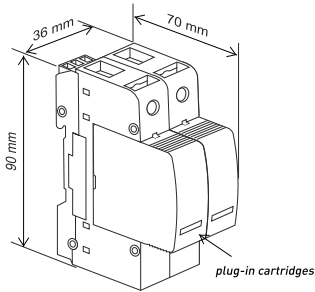

3 poles

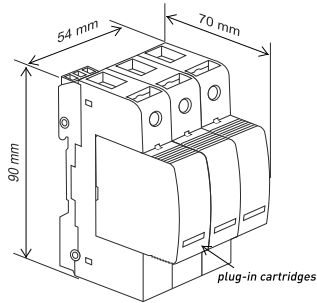

4 poles

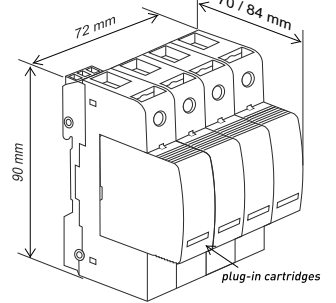

Electrical diagrams

A (1P)

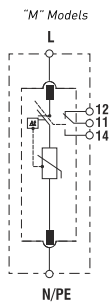

B (N)

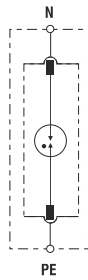

C 1+1 (2PG)

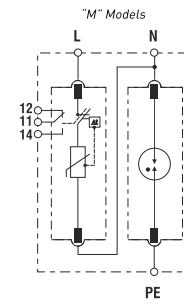

D 2+0 (2P)

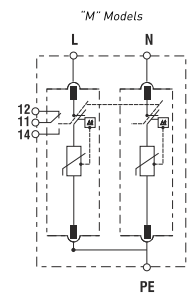

E 3+0 (3P)

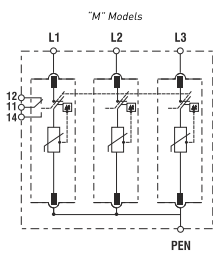

F 3+1 (3P reinforced)

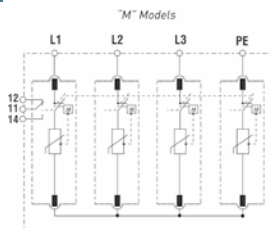

G 3+1 (4PG)

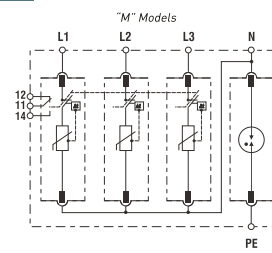

H 4+0 (4P)

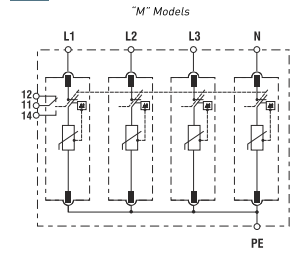

SURGE-TRAP® AC TYPE 2 PHOTOVOLTAIC SPD

STP T2 40

STP T2 40 3P is the series of type 2 /class II devices for discharging voltages surges, in accordance with IEC/EN 61643-11 and UL 1449. Suitable for the AC side protection in photovoltaic systems that provide power to the grid. Also suited for first or second stage of protection in commercial or residential applications.

Ratings and features

- Maximum discharge current (8/20µs): 40kA per phase
- Nominal discharge current (8/20µs): 20kA per phase
- TNS, TNC, TT and IT networks
- Un(L-N/L-L): 48V, 60V, 120/208V, 230/400V, 277/480V, 400/690V & higher
- DIN-rail mountable, plug-in format
- Visual and remote end of life indicators
- Reversible chassis to allow cable entry from above or below
- Mechanically coded cartridges to avoid cartridge replacement errors

Imax

40kA

LEARN MORE

ep.mersen.com

Approvals/Standards

- IEC/EN 61643-11
- UL 1449 4th Ed recognized, File No. E468946
- CE

Catalog numbers / Reference numbers

REFERENCE NUMBER	CATALOG NUMBER	Network								Cartridge Id.
		SYSTEM TYPE	ELECTRICAL DIAGRAM	UN [VAC]	UC [V]	IMAX (8/20) [KA]	IN (8/20) [KA]	UP@IN (8/20) [KV]	REMOTE INDICATION (M)	
83020134	STPT2-40K275V-3P	TNC (3Ph)	D	-/400	275	40	20	≤1.3		C23
83020135	STPT2-40K275V-3Pm	TNC (3Ph)	D	-/400	275	40	20	≤1.3	√	C23
83020136	STPT2-40K320V-3P	TNC (3Ph)	D	-/480	320	40	20	≤1.4		C24
83020137	STPT2-40K320V-3Pm	TNC (3Ph)	D	-/480	320	40	20	≤1.4	√	C24
83020102	STPT2-30K750V-3P	TNC (3Ph)	D	-/690; -/1000	750	30	15	≤3		C26
83020103	STPT2-30K750V-3Pm	TNC (3Ph)	D	-/690; -/1000	750	30	15	≤3	√	C26
83020246	STPT2-30K850V-3P	TNC (3Ph)	D	-/690; -/1000	850	30	15	≤3		C28
83020247	STPT2-30K850V-3Pm	TNC (3Ph)	D	-/690; -/1000	850	30	15	≤3	√	C28
83020100	STPT2-30K750V-1P	L-N (1Ph)	C	690	750	30	15	≤3		C26
83020101	STPT2-30K750V-1Pm	L-N (1Ph)	C	690	750	30	15	≤3	√	C26
83020234	STPT2-30K850V-1P	L-N (1Ph)	C	690	850	30	15	≤3		C28
83020235	STPT2-30K850V-1Pm	L-N (1Ph)	C	690	850	30	15	≤3	√	C28

Replacement cartridges

REF. NUMBER	CATALOG NUMBER	NETWORK	UN [VAC]	UC [V]	IMAX (8/20) [KA]	IN (8/20) [KA]	UP@IN (8/20) [KV]	CARTRIDGE ID.
83020002	SP2-40K275V	L-N (1Ph)	230	275	40	20	≤1.3	C23
83020003	SP2-40K320V	L-N (1Ph)	277	320	40	20	≤1.4	C24
83020007	SP2-30K750V	L-N (1Ph)	690	750	30	15	≤3	C26
83020022	SP2-30K850V	L-N (1Ph)	690	850	30	15	≤3	C28

Microswitch diagram

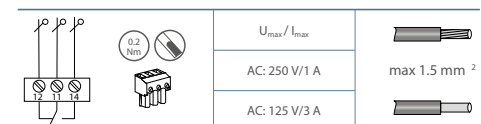

Dimensions

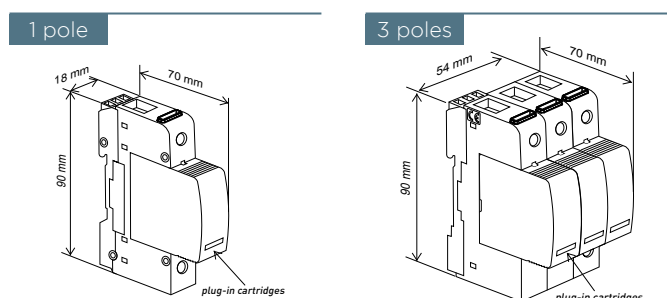

Electrical diagram

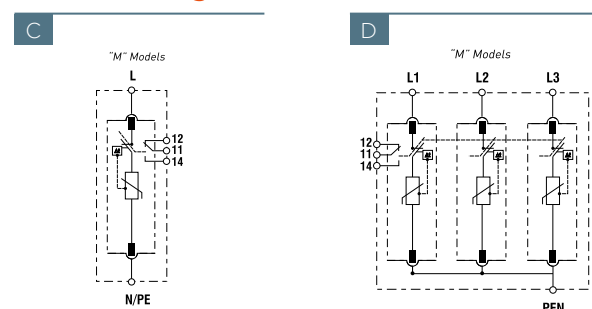

SURGE-TRAP® AC TYPE 2 REINFORCED PEAK WITHSTAND PHOTOVOLTAIC SPD

STP T2 30 3P-R

STP T2 30 3P-R is the series of type 2 /class II devices for discharging voltages surges, in accordance with IEC/EN 61643-11 and UL 1449. Suitable for the AC side protection in photovoltaic systems that provide power to the grid. Suitable for special applications where high withstand voltage peaks are required. PV grid side with induced DC offsets or wind turbine generators.

Ratings and features

- Maximum discharge current (8/20µs): 30kA per phase
- Nominal discharge current (8/20µs): 15kA or 20kA per phase
- TNC and IT networks
- Un(L-N/L-L): 400/690V & higher
- Voltage peak withstand up to 2,2kV
- DIN-rail mountable, plug-in format
- Visual and remote end of life indicators
- Reversible chassis to allow cable entry from above or below
- Mechanically coded cartridges to avoid cartridge replacement errors

Imax

30kA

[LEARN MORE](#)

ep.mersen.com

Approvals/Standards

- IEC 61643-11
- UL 1449 4th Ed recognized, File No. E468946
- CE

Catalog numbers / Reference numbers

REFERENCE NUMBER	CATALOG NUMBER	Network									Cartridge Id.	
		SYSTEM TYPE	ELECTRICAL DIAGRAM	UN [VAC]	UC [V]	IMAX (8/20) [KA]	IN (8/20) [KA]	UP@IN (8/20) [KV]	REMOTE INDICATION (M)	UPEAK (L-PE) [KV]	L	PE
83020177	STPT2-30K440V-3P-R	IT	A	- / 400	440	30	20	5		1,6	C25	C26
83020178	STPT2-30K440V-3P-RM	IT	A	- / 400	440	30	20	5	√	1,6	C25	C26
83020213	STPT2-30K750V-3P-R	IT	A	- / 690	750	30	15	6		2,1	C26	C26
83020214	STPT2-30K750V-3P-RM	IT	A	- / 690	750	30	15	6	√	2,1	C26	C26
83020201	STPT2-30K850V-3P-R	IT	A	- / 690	850	30	15	6		2,2	C28	C28
83020202	STPT2-30K850V-3P-RM	IT	A	- / 690	850	30	15	6	√	2,2	C28	C28

Replacement cartridges

REF. NUMBER	CATALOG NUMBER	NETWORK	UN [VAC]	UC [V]	IMAX (8/20) [KA]	IN (8/20) [KA]	UP@IN (8/20) [KV]	CARTRIDGE ID.
83020004	SP2-40K440V	L-N [1Ph]	400	440	40	20	≤2	C25
83020007	SP2-30K750V	L-N [1Ph]	690	750	30	15	3	C26
83020022	SP2-30K850V	L-N [1Ph]	690	850	30	15	3	C28

Microswitch diagram

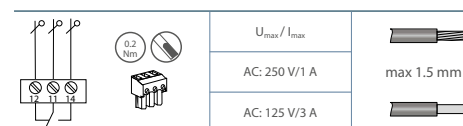

Dimensions

4 poles

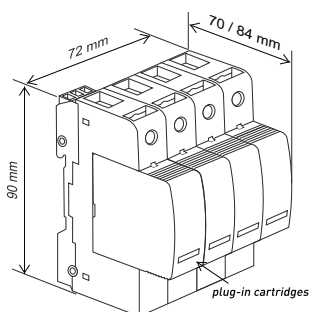

Electrical diagram

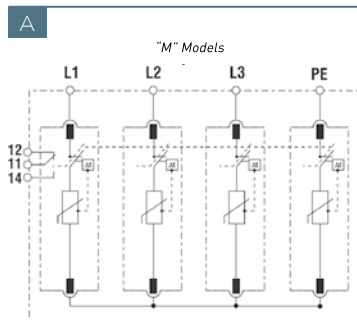

SURGE-TRAP® SIGNAL LINE PHOTOVOLTAIC SPD

STS 485

STS 485 is the new series of type D1 and C2 surge protection devices for signal lines in accordance with IEC/EN 61643-21. Especially designed for protecting RS485/RS232 communication lines used in PV applications against induced overvoltages. Suitable as a dedicated protection for special equipment connected to communication lines (i.e. string monitor), providing extremely fine voltage protection level and an optimal discharge capacity.

Ratings and features

- Maximum discharge current (8/20): 10kA (I_{max})
- Type D1 maximum discharge current (10/350µs): 2,5kA (I_{imp})
- Type C2 nominal discharge current (8/20µs): 5kA (I_n)
- Models with end of life indication
- Multiple voltage options for different protocols (6, 12, 24V)
- Operational bandwidth (fg) up to 10MHz
- Extremely fine voltage protection level
- DIN rail mountable, monobloc format

Catalog numbers / Reference numbers

REFERENCE NUMBER	CATALOG NUMBER	ELECTRICAL DIAGRAM	U _n [V]	D1 (10/350) [KA]	IMAX (8/20)	C2 (8/20)	UP@IN (8/20) [V]	fg [MHz]	PROTECTED WIRES	EOL INDICATION
83040111	STS485-7V-2W	E	6	2,5	10	5	10	1	2	
83040112	STS485-16V-2W	E	12	2,5	10	5	20	1,2	2	
83040113	STS485-27V-2W	E	24	2,5	10	5	40	4	2	
83040114	STS485-56V-2W	E	48	2,5	10	5	70	5	2	
83040110	STS485-15V-3WI	F	12	2,5	10	5	45	10	2+GND	√
83040120	STS485-5V-4WG	G	5	2,5	10	10	30	60	4+GND	

Dimensions

1 pole (2w)

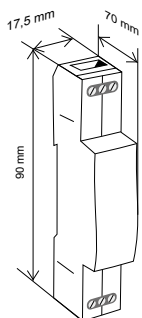

1 pole (3w)

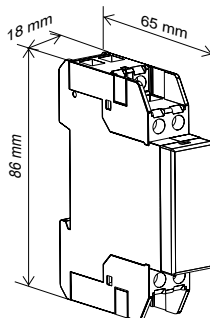

2 poles (4w)

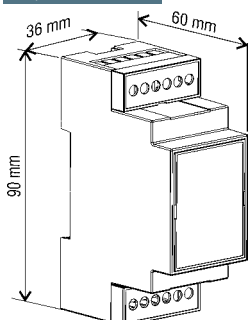

I_{max} 
10kA

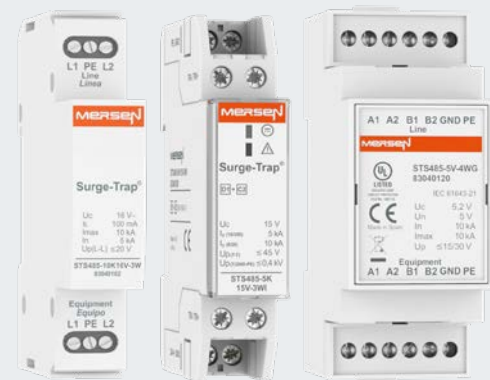

Approvals/Standards

- IEC/EN 61643-21
- UL 497B
File No. E496110
- CE



Electrical diagram

E

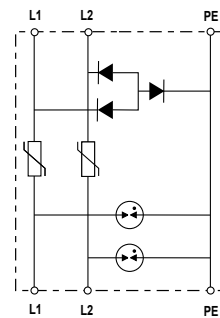

F

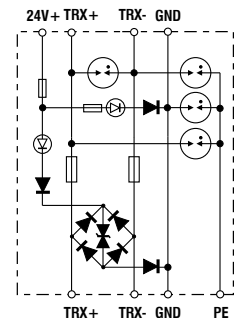

G

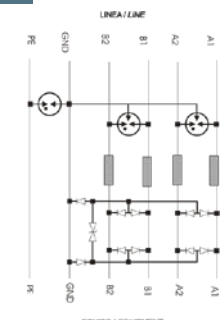

NOTES

Lined area for taking notes, consisting of multiple horizontal dashed lines.

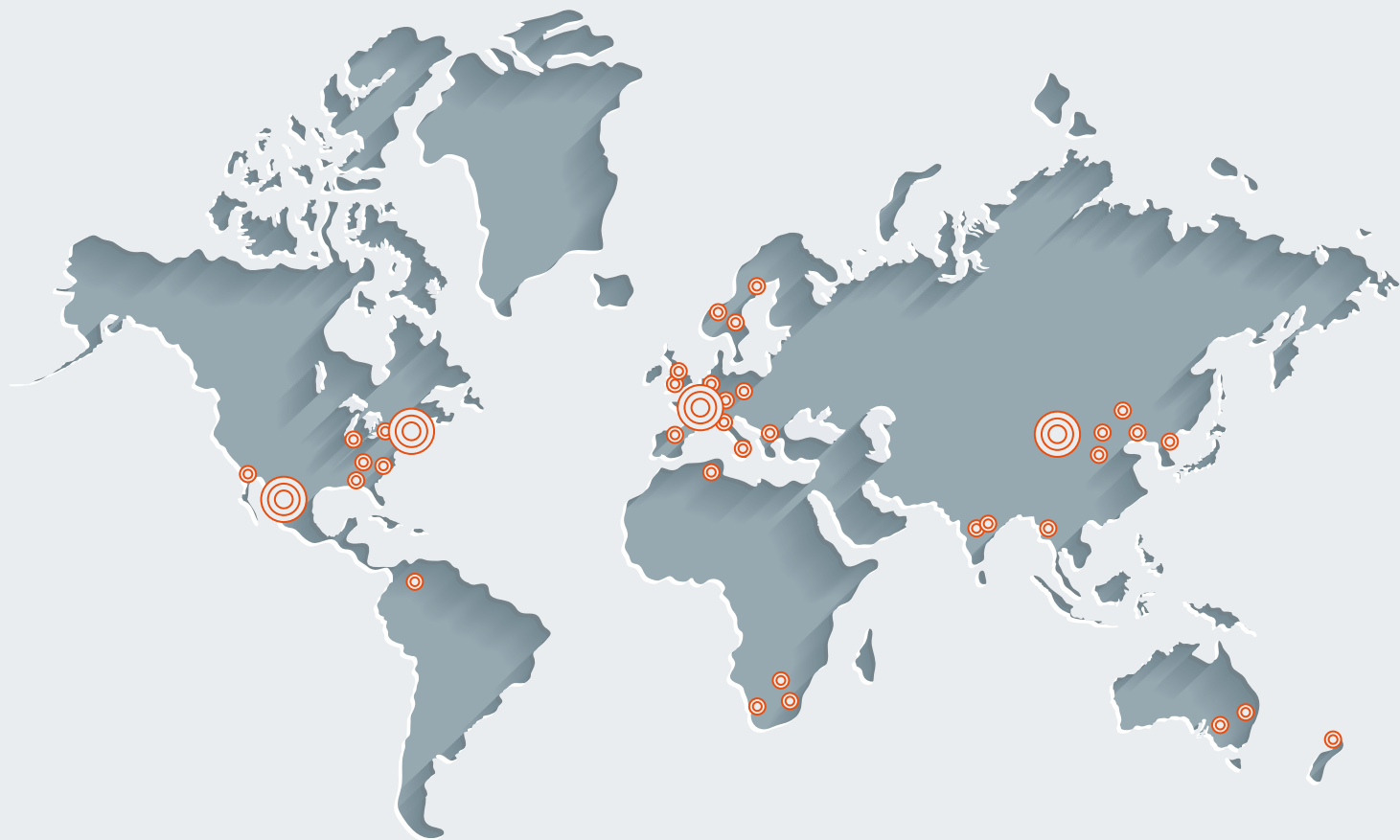

GLOBAL EXPERT
IN ELECTRICAL POWER
AND ADVANCED MATERIALS.

EUROPE

FRANCE
Mersen France SB S.A.S.
Rue Jacques de Vaucanson
F-69720 Saint-Bonnet-de-Mure
Technical & Applications Support:
inquiry.sbm@mersen.com

NORTH AMERICA

USA
Mersen USA
Newburyport-MA L.L.C.
374 Merrimac Street
Newburyport, MA 01950
Tel: +1 978-462-6662

ASIA

CHINA
Mersen Shanghai Co. Ltd.
No.55-A6, Shu Shan Road, Songjiang
201611 Shanghai
Tel: +8621 67602388



EP.MERSEN.COM